

# **SKYLINE**<sup>®</sup>



## **TRAVEL TRAILER FIFTH WHEEL OWNERS MANUAL**

**SKYLINE**<sup>®</sup>

BRINGING AMERICA HOME. BRINGING AMERICA FUN.

This Quality Recreational Vehicle Built By:

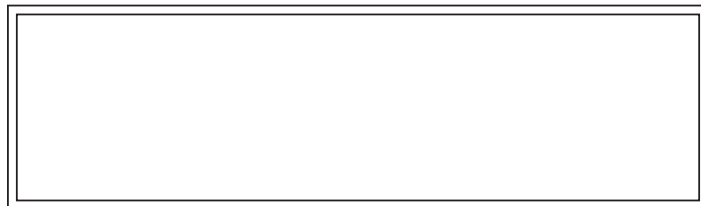

# Table Of Contents

<b>Introduction</b> .....	3	Generator (Optional).....	28	Frame and Chassis .....	55
Danger, Warning, Caution and Note Boxes.....	4	Microwave (Optional) .....	28	Tires and Wheels .....	56
<b>Chapter 1:</b> <b>Warranty Information</b> .....	5	Range/Oven (Optional).....	29	Battery.....	60
Owner's Responsibilities .....	5	Refrigerator.....	30	Bedspreads.....	61
Dealer Responsibilities .....	5	Roof Vents.....	31	Blinds and Shades.....	61
Full One-Year Warranty .....	5	Safety .....	31	Cabinet Doors and Drawers (Wood) .....	61
Owner Responsibility .....	5	Propane, Carbon Monoxide Detectors, and Smoke Alarms .....	33	Carpeting.....	61
Obtaining Warranty Service .....	5	<b>Chapter 5:</b> <b>Electrical System</b> .....	34	Ceilings and Walls.....	61
Inspection .....	6	12 Volt System — DC.....	34	Counter Tops .....	61
Unit Information Packet .....	6	110 Volt System (Also referred to as 120) — AC.....	35	Draperies.....	61
Get To Know Your Unit Before Heading Out.....	6	Power Cord/Shore Cord .....	35	Faucets and Fixtures .....	61
If You Need to Make an Appointment .....	6	30 Amp, 50 Amp and Available Power .....	35	Flooring, Vinyl .....	61
<b>Chapter 2:</b> <b>Effects of Prolonged Occupancy</b> .....	7	Converter .....	36	Glass and Mirrors .....	61
Ventilation, Condensation and Moisture Management.....	7	GFCI (Ground Fault Circuit Interrupter).....	37	Fabric and Upholstery.....	61
Storage of Your RV .....	9	7-Way Plug .....	37	Sinks, Tubs and Toilets.....	61
Wet Areas .....	9	Brakes, Electric.....	38	Tables and Beds.....	62
Mold.....	10	Breakaway Switch .....	38	Storage .....	64
<b>Chapter 3:</b> <b>Towing and Leveling</b> .....	11	<b>Chapter 6:</b> <b>Propane Gas System</b> .....	40	Maintenance Schedule .....	65
Towing Guidelines .....	12	General Information.....	40	<b>Chapter 10:</b> <b>Tire Safety Information</b> .....	67
Weight Ratings — Definitions .....	12	Propane Regulator .....	40	Safety First — Basic Tire Maintenance .....	68
Weight Ratings — Labels.....	12	Propane Gas Lines .....	41	Finding Your Vehicle's Recommended Tire Pressure and Load Limits.....	68
Loading and Weighing Your Unit.....	14	Propane Gas Leak Detector .....	41	Understanding Tire Pressure and Load Limits.....	68
Special Transportation Provisions .....	16	<b>Chapter 7:</b> <b>Plumbing System</b> .....	42	Checking Tire Pressure .....	68
Hitches and Towing .....	17	Water Pump .....	42	Steps for Maintaining Proper Tire Pressure .....	68
Before Heading Out.....	18	Fresh Water Tank .....	43	Tire Size.....	69
Tire Safety Tips .....	19	Sanitizing Fresh Water System .....	44	Tire Tread .....	69
While Driving .....	20	Water Heater .....	44	Tire Balance and Wheel Alignment .....	70
Leveling Procedures .....	23	By-Pass Kit (Optional) .....	46	Tire Repair .....	70
Stabilizing Jacks .....	23	Monitor Panel .....	46	Tire Fundamentals .....	70
Ramp Trailer Weight Distribution.....	24	Winterization .....	46	Information on Passenger Vehicle Tires .....	70
<b>Chapter 4:</b> <b>Appliances and Equipment</b> .....	24	Waste Water System.....	48	Additional Information on Light Truck Tires.....	71
What to do if You Smell Gas.....	24	Holding Tanks .....	48	Vehicle Load Limits .....	72
Air Conditioner (Optional) .....	24	No Fuss Flush (Optional).....	49	Cargo Capacities .....	72
Antenna (TV).....	25	Toilet.....	49	How Overloading Affects Your RV and Tires .....	72
Awning, Patio (Optional).....	25	<b>Chapter 8:</b> <b>Slide-Out Systems &amp; Ramp Doors</b> .....	51	Tire Safety Checklist .....	73
Cable Hook-Up.....	26	Electric Slide-Out .....	52	Steps for Determining Correct Load Limit.....	73
Fan-Tastic Vent™ (Optional) .....	26	Slide-Out Rear Bead .....	53	<b>Appendix</b> .....	74
Furnace .....	26	Ramp Door.....	53	Exterior Pre-Travel Checklist .....	74
Fueling Station (Optional) .....	27	<b>Chapter 9:</b> <b>Care and Maintenance</b> .....	53	Interior Pre-Travel Checklist .....	74
		Exterior .....	54	Glossary of Common RV Terms .....	76
		Roof .....	54		
		Seals and Adhesives .....	55		
		Windows (Exterior) .....	55		

# Skyline Cares About You

Skyline is a leader in the recreational vehicle industry because Skyline cares about its RV owners. Your investment in your Skyline-built travel trailer is protected by Skyline's extensive five-point program:

1. **Product design and engineering.** Skyline maintains a complete staff of professional engineers and designers.
2. **Code construction.** Every travel trailer built by Skyline meets or exceeds code standards and features quality components including name brand appliances.
3. **Full one-year warranty.** It's the no-nonsense guarantee printed in this manual. We urge you to read it.
4. **Full field service.** Skyline and its dealers are pledged to back up the warranty with prompt, courteous service that takes care of problems quickly and effectively.
5. **Financial strength.** Skyline is one of America's soundest companies financially. You can rely on Skyline today — and tomorrow.

To further ensure your satisfaction:

1. Your travel trailer is inspected by your dealer after it leaves the factory and before it is delivered to you.
2. Upon taking delivery, have your dealer go over your travel trailer with you and instruct you concerning the appliances and other working parts. Be sure to ask your dealer to demonstrate the operation of any appliance or item of equipment which you do not understand.
3. As with your other vehicles, your travel trailer will require regular care and maintenance. This manual, together with the information provided by manufacturers of various components, provides a maintenance schedule that you can and should follow to ensure safe, trouble-free service from your trailer. Studying these instructions carefully and maintaining a good working knowledge of your trailer and how to care for it will help you enjoy it for many miles and many years.

If you should have a problem that is not resolved to your satisfaction by your local dealer, call or write the service manager at the factory nearest you. A list of factories can be found in this manual.

All of us at Skyline join with your dealer in wishing you every happiness in your new travel trailer.

## Introduction

We're delighted that you chose to invest in a Skyline-built trailer. Your new travel trailer is designed and constructed to make each trip as safe and carefree as possible, and we won't be satisfied until you're completely happy with it.

Before your first trip, please take the time to read this manual and the appliance and other manuals that come with it. They will help you to get the most enjoyment out of your purchase.

All manuals should be kept available for easy reference.

**NOTE:** Some equipment and features described or shown in this manual may be optional on some Skyline models. The term "travel trailer" as used in this manual includes fifth wheel travel trailers unless otherwise indicated.

[www.skylinerv.com](http://www.skylinerv.com)

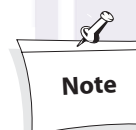

### IMPORTANT SAFETY MESSAGE

**Don't take chances with safety. The heating, cooking, electrical, and other systems and appliances in your travel trailer must be operated and maintained ONLY as specified in this manual and in other manuals furnished with it. Check your manual and be sure you clearly understand how to operate any system before you try it. If you are at all uncertain, contact your dealer, the Skyline factory, the system or appliance manufacturer's local representative, or Skyline's Director of Consumer Affairs BEFORE you operate any system or appliance.**

## Skyline Customer Satisfaction

Skyline Customer Satisfaction is more than just a promise — We believe you deserve quality in every aspect of ownership. To ensure your continued satisfaction we're dedicated to providing you with a quality product along with the very best service available in our industry. Skyline's *'Commitment of Excellence'* will be a source of pride and satisfaction for you.

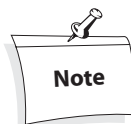

This manual is based on the latest information available at the time of publication. Due to continuous product development and improvements, Skyline reserves the right to make changes in product specifications and components without prior notice.

<b>SKYLINE</b>	
<i>Commitment of Excellence</i>	
OWNER SATISFIED CUSTOMER	
ORIGINAL DEL. DATE 11-15-93	SEALER NO. 45454
VEHICLE I.D. NO. 7600	MODEL NO. 2955
BRINGING AMERICA HOME. BRINGING AMERICA FUN.	

## Danger, Warning, Caution and Note Boxes

We have provided many important safety messages in this manual. Always read and obey all safety messages.



DANGER indicates an imminently hazardous situation that, if not avoided, will result in death or serious injury.



WARNING indicates a potentially hazardous situation that, if not avoided, could result in death or serious injury.



CAUTION indicates a potentially hazardous situation that, if not avoided, may result in minor or moderate injury.

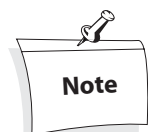

Important information regarding the maintenance of your recreational vehicle.

## Terms and Symbols Used (Optional)

This denotes items that may be an option on all or particular models. Additionally, some optional items can only be included during the manufacturing phase and cannot be added.

The inclusion of optional items does not imply or suggest the availability, application suitability or inclusion for any specific unit.

# Chapter 1: Warranty Information

As the owner of a new recreational vehicle, you are responsible for regular care and proper maintenance. Proper maintenance will help avoid situations where the Full One-Year Warranty will not cover items due to neglect. Maintenance services should be performed in accordance with this manual, as well as the corresponding manufacturers' warranties on components included within your trailer.

## Owner's Responsibilities

1. Proper care and maintenance as outlined in this manual and the corresponding component warranty package
2. Returning your vehicle to an authorized dealer for any repairs or service that is required
3. Reviewing the information contained within this manual and all supplied component information

## Dealer's Responsibilities

1. Orient and familiarize the customer with the operation of all systems and components of the new recreational vehicle
2. Explain and review the Full One-Year Warranty provisions to the customer
3. Assist the customer in completing all necessary registrations and warranty cards for their new vehicle and assist in locating serial numbers if they wish
4. Instruct the customer on how to receive local and out-of-town service on the vehicle
5. Complete pre-delivery inspection
6. Enter owner information on line at [www.skylinecorp.com](http://www.skylinecorp.com)

## Full One-Year Warranty

*Manufacturing defects reported to Skyline within one year after original retail delivery of your new Travel Trailer by an authorized dealer will be corrected without charge and within reasonable times. Excluded are misuse (including lack of reasonable maintenance), minor imperfections, alterations, and dealer or owner improper transportation, installation or hookup.*

*This warranty gives you specific legal rights. You may have other rights which vary from state to state.*

*Skyline's suppliers often provide additional warranties on their components beyond the Skyline factory bumper-to-bumper warranty. For example — the range, water heater, furnace and convertor carry two-year supplier warranties while the air conditioner, refrigerator, microwave and awning carry three-year warranties. The one-piece roof carries a 12-year warranty. Ask your dealer for full details.*

## Owner Responsibility

It is the responsibility of the owner to maintain the recreational vehicle as described in the Care and Maintenance section of the Owner's Manual including taking whatever preventative measures necessary to maintain the exterior sealants of the unit and to prevent foreseeable secondary moisture or water damage to the unit from rain, plumbing leaks, condensation and other natural accumulation of water in the unit. Examples of secondary damage include, but are not limited to, stained upholstery, carpeting or drapes, mold formation and growth, furniture, cabinetry or floor deterioration, etc. Mold is a natural growth given certain environmental conditions and is not covered by the terms of the Warranty. See the separate section on mold.

## How To Obtain Warranty Service

Your continued satisfaction with your travel trailer is of utmost importance to Skyline. Please follow these steps for fast, efficient warranty service.

1. Inspect your travel trailer thoroughly to determine exactly what service is required.
2. Make a list of the required service. Be sure to sign it.
3. Call, write or visit your dealer.

If your request is not resolved to your satisfaction, make sure it is brought to the attention of the owner or general manager of the dealership. They will obtain factory assistance, if needed.





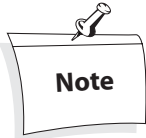

Your appliances are warranted both by the appliance manufacturer and by Skyline. All appliances furnished with your travel trailer are “name-brands”, and the manufacturer may have a service facility near you. If so, you may be able to obtain even faster service by requesting service directly from the appliance manufacturer.



Please have the following available when you call:

- Vehicle Identification Number (17-digit or Serial Number)
- Model #
- Date of Purchase
- Description of the problem
- Previous repair history and location (if applicable).

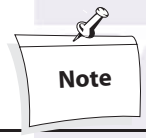

Please note, your Skyline Warranty covers warrantable repairs that are performed by an authorized Skyline dealer at their service center or facility only. It is important for the owner to know that if you are unable to bring your unit in for repairs, Skyline is not responsible for any costs incurred for the service call charge, or time accrued to come out to your unit. Your unit is a recreational vehicle and not intended, nor manufactured, as a permanent residence. Long-term or full-time occupancy may lead to premature deterioration and may, under the terms of the warranty, constitute misuse and reduce your warranty protection.

4. Factory: If your request has not been resolved to your satisfaction within a reasonable time, write (include the complete serial number of your travel trailer and your telephone number with a copy of your list of required service) and/or call the factory service representative below, or E-Mail us at, [crelations@skylinecorp.com](mailto:crelations@skylinecorp.com).

5. In those rare cases in which your dealer and the factory service representative have been unable to resolve the problem, write the Director of Consumer Affairs, Skyline Corporation, P.O. Box 743, Elkhart, Indiana 46515-0743, or at [crelations@skylinecorp.com](mailto:crelations@skylinecorp.com). Include the complete serial number of your travel trailer, your telephone number and a complete list of the required manufacturer’s warranty service. Your request will receive prompt attention.

All service under your Skyline warranty will be performed without charge for either parts or labor. Whether service is performed by the dealer, the factory or others, Skyline accepts final responsibility for fulfillment of all its warranty obligations. Skyline will use its best efforts to see that all manufacturer’s warranty service is completed as expeditiously as possible.

Warranty service requests must be made within the warranty period and should ordinarily go to your dealer.

## Inspection

To assist you in avoiding problems, Skyline requests that each dealer review the warranty and inspect the unit along with you. The dealer has been provided with a pre-delivery checklist. Review this checklist with the dealer. Do not sign the checklist until this review is complete and any questions about anything you do not understand have been answered.

## Unit Information Packet

In addition to this Owner’s Manual, a unit information packet is located within your new recreational vehicle. Inside the packet are product manuals and information on systems and equipment in the trailer. Individual product warranty registrations accompany this information and should be completed and mailed promptly. Some components in this manual or packet may be components of a differing product line and/or are optional equipment. Inclusion of these items does not suggest that they are or may be available for a specific recreational vehicle.

## Get To Know Your Unit Before Heading Out

Throughout the manufacturing process, your recreational vehicle has been inspected by qualified inspectors and then again at the dealership. As the owners, however, you will be the first to camp and extensively use every system. Skyline wants the first camping experience to a be happy one and recommends a “Trial Camping Experience” before heading out. Plan a weekend in the yard or driveway and really camp in your unit.

By camping for several days, full-time in your unit, you will have the opportunity to use and become accustomed to the systems within your unit and find out what items are needed/not needed while camping. Note any questions that arise, difficulties encountered or problems that occur. After your trial, call your dealer and ask any questions that have arisen. Getting to know your unit before the first adventure can save a lot of frustration and leave more time for fun!

## If You Need to Make an Appointment

### Call Ahead

Give thought to an appointment time and call ahead. Mondays and Fridays are generally the busiest times at a dealer’s service center, as are right before seasonal holidays.

### Be Prepared

If warranty work is to be done, please have a copy of your warranty paperwork available and provide the service center with any helpful information on past repairs that may pertain and help the technicians in diagnosing the problem.

### **Make a List**

Have a list ready and be reasonable with repair expectations. Some repairs may require special order parts or parts shipped from a manufacturer. Explain what you would like to have done over the phone or stop by ahead of time so that you and the service manager can discuss possible repair times.

### **While Waiting**

Drop your unit off if possible. If you wait on your repair, do not be surprised if you cannot enter the repair area. Many insurance policies prohibit customers or non-employees from entering into the work area for safety reasons.

### **Inspecting Your Repairs**

Skyline and your dealer want you to be satisfied with any repair. After a repair is performed, inspect thoroughly. Check off your list and go over the repairs with the service center representative. Once satisfied, sign the Skyline Service Form. In the event a problem should recur after you have left the dealership, contact the repair center or Skyline as soon as possible, so that the situation can be resolved expeditiously.

---

## **Chapter 2: Effects of Prolonged Occupancy**

Your recreational vehicle was designed primarily for recreational use and short-term occupancy. If you expect to occupy the coach for an extended period, be prepared to deal with condensation and the humid conditions that may be encountered. The relatively small volume and tight compact construction of modern recreational vehicles means that the normal living activities of even a few occupants will lead to rapid moisture saturation of the air contained in the trailer and the appearance of visible moisture, especially in cold weather.

Just as moisture collects on the outside of a glass of cold water during humid weather, moisture can condense on the inside surfaces of the recreational vehicle during cold weather when relative humidity of the interior air is high. This condition is increased because the insulated walls of a recreational vehicle are much thinner than house walls. Estimates indicate that a family of four can vaporize up to three gallons of water daily through breathing, cooking, bathing and washing.

Unless the water vapor is carried outside by ventilation or condensed by a dehumidifier, it will condense on the inside of the windows and walls as moisture or in cold weather as frost or ice. It may also condense out of sight within the walls or the ceiling where it will manifest itself as warped or stained panels. Appearance of these conditions may indicate a serious condensation problem. When you recognize the signs of excessive moisture and condensation in the trailer, action should be taken to minimize their effects.

## **Ventilation, Condensation and Moisture Management**

The following steps should be taken to aid in eliminating internal moisture condensation:

### **Interior Care of Your RV**

Signs of excessive moisture can be obvious, such as water droplets forming on surfaces or wet carpet. Conversely, signs of excess moisture can be subtle, such as condensation forming on metal surfaces. When symptoms appear it is important to timely determine the cause of the excess moisture and take appropriate corrective action to prevent moisture related damage.

### **Control Relative Humidity**

Monitoring and controlling relative humidity within the RV is one of the most important steps to minimize the risk for moisture-related damage. Ideally, relative humidity should be at 60% or less. Relative humidity can be monitored utilizing a portable hygrometer, a small device that measures temperature and relative humidity. Hygrometers are available at electronics or building supply stores for approximately thirty dollars (\$30).

Use exhaust fans, the air conditioner, and/or a portable dehumidifier to manage moisture inside the RV to maintain relative humidity at 60% or less. In cold climates, relative humidity may need to be at 35% or less to avoid window condensation issues.

If the RV is used the majority of the time in a hot-humid climate, it may be difficult to keep relative humidity below 60%. A dehumidifier will help, but it is important to check the condensation (water) collection bucket regularly or discharge the condensation (water) directly to a drain.



---

### **Tow Vehicle Disclaimer**

In connection with the use and operation of Skyline recreational vehicles, Skyline customers and owners of Skyline recreational vehicles are solely responsible for the selection and proper use of tow vehicles. All customers should consult with a motor vehicle manufacturer or dealer concerning the purchase and use of suitable tow vehicles for Skyline products. Skyline further disclaims any liability with respect to damages which may be incurred by a customer or owner of Skyline recreational vehicles as a result of the operation, use or misuse of a tow vehicle. NOTE: SKYLINE'S WARRANTY DOES NOT COVER DAMAGE TO THE RECREATIONAL VEHICLE OR THE TOW VEHICLE AS A RESULT OF THE OPERATION, USE OR MISUSE OF THE TOW VEHICLE.

---



### **Avoid Drastic Thermostat Setbacks**

Cooler surface temperatures increase the potential for condensation and surface mold growth. To minimize the opportunity for condensation to form on interior surfaces, maintain a comfortable temperature in your RV, and avoid nighttime setbacks of 10 degrees or more. Drastic setbacks that reduce the indoor air temperature quickly can increase the chance for airborne moisture to condense on cool surfaces such as windows. If you are away from your RV for an extended number of days, we recommend that you do not set the temperature back without taking other measures to manage relative humidity, including operating a dehumidifier with a continuous drain.

### **Manage Window Condensation**

Window condensation issues can be identified by water or ice build up, usually at the base of the window. The majority of these problems can be addressed by managing moisture generated inside the RV. Minor condensation issues are not unusual, especially for RVs used in colder climates. The key is to manage this small amount of moisture if evident by wiping the surface, and as discussed above, maintaining a reasonable relative humidity within the unit.

Storm windows are available from your Skyline Dealer. The interior surface of the storm windows will be at least 20 degrees warmer, reducing moisture condensation. Do not cover emergency exit windows. The emergency exit windows must be accessible at all times.

To help minimize window condensation, use exhaust fans vented to the outside, avoid drastic changes in thermostat settings, do not use 'vent-free' heaters and use window coverings wisely. For example, make sure to open curtains or blinds during the day to allow air to circulate and warm the window surface.

### **Carpet Care and Moisture Management**

To keep your carpet serviceable and looking new for years to come, the carpet should be cleaned when it shows signs of discoloration or traffic patterns. A steam cleaning system may be used to clean the carpet. To manage moisture from the cleaning process, the cleaning system needs to be capable of extracting the excess water from the carpet after it has been cleaned. Important: Be sure the carpet is thoroughly dry before closing up the RV for storage. Water from the cleaning process can cause significant damage to the RV if the carpet is not completely dry before closing up the RV.

### **Cleaning Tile and Wood Floors**

The tile or wood floor installed in your RV require only a mild detergent and warm water for cleaning. More water on the floor is not always better for cleaning. Use a damp cloth to clean on a regular basis rather than wet mopping each time. Be careful to keep any water from cabinet faces. Prolonged exposure can cause discoloration or swelling.

### **Storage and Other Isolated Areas Within the RV**

Storage areas are more difficult to condition since the areas are isolated from the main body of the RV. The surfaces of these areas are more at risk for condensation and surface mold growth. To minimize this risk, clean storage areas regularly, and allow an air space between stored items and the exterior wall to promote air circulation.

During prolonged use of the recreational vehicle in very cold weather, closet and cabinet doors should be left partially open in order to ventilate the interiors of storage compartments built against exterior walls. The air flow will aid in warming exterior walls, assist in reducing or eliminating condensation, and prevent possible ice formation.

### **Use of Unvented Combustion Equipment**

Unvented combustion equipment, such as propane stovetops, are a source of moisture within the RV. For every gallon of fuel consumed, approximately one gallon of water vapor is evaporated into the air. Whenever possible, operate an exhaust fan in combination with the use of any unvented combustion appliance within the RV. Water vapor and other combustion by-products should be vented to the exterior of the RV. The RV owner should strictly follow use and maintenance instructions for safe operation of any combustion equipment, particularly unvented equipment.

In addition to the dangers of toxic fumes and oxygen depletion which makes heating with the range or oven very dangerous, open flames add moisture to the interior air, increasing condensation. Do not use an air humidifier inside the trailer.

### **Use of Your RV**

It is important to remember that the square footage of an RV is significantly less than that of a single family residence. This fact alone will elevate the relative humidity because there is less volume of air to help absorb or dissipate the humidity. For example, showering and cooking create a lot of humidity in a small area. In these instances, use of an exhaust fan and opening windows should reduce the relative humidity, particularly when living in the RV for an extended period.



**DO NOT HEAT THE TRAILER WITH RANGE OR OVEN.**



Ventilate your recreational vehicle regularly by partially opening roof vents and one or more windows. Use vents when using the range or bath or shower. While this venting will increase the furnace heating load, it will greatly reduce, or eliminate, water condensation. NOTE: Even when it is raining or snowing, ventilation air from outside will be far drier than interior air and will effectively reduce condensation.

Remember to run the range vent fan when cooking and the bath vent fan (or open bath vent) when bathing to carry water vapor out of the trailer. Avoid excessive steam resulting from boiling water or use of hot water. Remove snow or water from shoes or boots before entering the trailer to avoid soaking carpet.

Also avoid drying overcoats or other clothes inside the trailer.

### Severe Environments

Prolonged use of your RV in severe environments — for example in extremely cold or hot-humid climates, will require extra care and maintenance to avoid moisture-related issues.

In both extremely cold and hot-humid climates, more attention needs to be focused on controlling relative humidity within the RV. It also may require the use of a portable dehumidifier to manage relative humidity within an acceptable range.

### Exterior Care Of Your RV

The exterior shell of the RV is the primary weather and moisture barrier. Over the life of the RV, the shell will require regular care and maintenance in accordance with the owner's manual. The shell includes the roof, sidewalls, windows, doors, and under-floor. Particular attention needs to be devoted to ensure these components are maintained to ensure a tight barrier against bulk water intrusion.

The shell should be inspected periodically for tears, gaps, and condition of sealants in accordance with your owner's manual. Areas that require maintenance should be resealed utilizing a similar, high quality sealant used by the manufacturer.

Particular attention should be devoted to ensure the slide out(s) are functioning properly. Each time a slide out is used it should be inspected to ensure proper operation and sealing. The slide out gaskets should also be inspected to ensure proper sealing when the slide out is operated.

### Storage of Your RV

During those periods when your RV is not in use, care must be taken to ensure moisture sources are addressed. Ideal storage of your RV would be in an enclosed climate controlled environment. When this is not possible, the following steps should be taken to ensure moisture is controlled:

- Turn off all water sources;
- Turn off all combustion appliances;
- Drain the water tank(s);
- Drain the water heater;
- Open all closets, cabinet doors and drawers;
- Close all windows and entrance doors;
- Open a vent or a window enough to allow for some limited ventilation air flow, but not so far as to allow snow or rain to enter;
- When storing the RV in high humidity climates (ambient relative humidity is greater than 60% year round), add a dehumidifier drained to exterior to control humidity inside the RV during storage.

### Wet Areas

Areas that are exposed to water spills or leaks should be dried as soon as possible and definitely within 24-48 hours. Drying areas quickly minimizes the chance for moisture damage and possible mold growth, which can begin to form colonies in 24-48 hours. A variety of methods can be used to help the drying process:

- Remove excess water with an extraction vacuum.
- Use a dehumidifier to aid drying.
- Because moisture is key to mold issues, treat all signs of condensation and spills seriously and deal with promptly. Failure to deal with a moisture issue promptly may cause more severe issues where none initially existed, or may make a small problem much worse.
- Be sure to understand and eliminate the source of moisture accumulation as a part of the clean-up. Otherwise, the same issues will simply recur; and

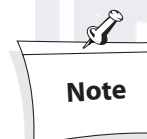

**Remember, your trailer is not designed, nor intended, for permanent housing. Use of this product for long-term or permanent occupancy may lead to premature deterioration of structure, interior finishes, fabrics, carpeting and drapes. Damage or deterioration due to long-term occupancy may not be considered normal and may, under the terms of the warranty, constitute misuse, abuse or neglect and may therefore reduce the warranty protection.**

- Small amounts of mold should be cleaned as soon as they appear. Small areas of mold should be cleaned using a detergent/soapy solution or an appropriate household cleaner. Gloves should be worn during cleaning. The cleaned area should then be thoroughly dried. Dispose of any sponges or rags used to clean mold.

Also see separate section below on mold in this manual.

## Mold

Mold is a fungus that occurs naturally in the environment, and it is necessary for the natural decomposition of plant and other organic material. It spreads by means of microscopic spores borne on the wind and is found everywhere life can be supported. Recreational vehicle construction is not, and cannot be, designed to exclude mold spores. If the growing conditions are right, mold can grow in your recreational vehicle. Most people are familiar with mold growth in the form of bread and cheese mold, and the mold that may grow on bathroom tile.

In order to grow, mold requires a food source. These food sources might be supplied by items found in the recreational vehicle, such as fabric, carpet, wallpaper, or building materials (i.e., wood, and insulation). Also, most mold growth requires a temperate climate. The best growth occurs at temperatures between 40°F and 100°F. Finally, mold growth requires moisture. Moisture is the only growth factor that can be controlled. By minimizing moisture, an owner can reduce or prevent mold growth.

Moisture can stem from a variety of sources such as spills, leaks, overflows, condensation, damp or standing water and human activity such as showering or cooking. Good housekeeping and maintenance practices are essential in the effort to prevent or reduce mold growth. You should keep the humidity in your unit below 60% (35% in colder climates). If optimal growth conditions persist, mold can develop within 24 to 48 hours.

### Consequences of Mold

Experts disagree about the level of mold exposure that may cause health problems, as well as the exact nature and extent of the health problems that may be caused by mold. Some people are allergic to mold and may suffer hayfever like allergic symptoms. Other, more serious health effects have also been attributed to exposure to mold. The immunocompromised (people with immune deficiencies or on chemotherapy), elderly, children and persons with asthma or other chronic respiratory disease may be at greater risk of adverse health effects. If you have any of these conditions or are concerned that you may be exposed to mold which could cause adverse health conditions you should consult with a qualified health care provider.

### What You Can Do

Take positive steps to reduce the occurrence of mold growth, and thereby minimize any possible adverse effects that may be caused by mold. These steps include the following:

1. Before bringing items into the recreational vehicle, check for signs of mold. Potted plants (roots and soil), furnishings, or stored clothing and bedding material, as well as many other household goods, could already contain mold growth.
2. Regular vacuuming and cleaning will help reduce levels of settled mold spores. Detergent solutions and most tile cleaners are effective in controlling mold growth on surfaces. If other biocides or mild bleach solution are used, care must be taken in handling these solutions.
3. Keep the humidity below 35-60%. Generally the lower the outside temperature the lower the inside humidity must be. Do not hang clothes to dry indoors. Ventilate kitchens and bathrooms by opening windows, using exhaust fans, or running the air conditioning, if so equipped, to remove excess moisture in the air and to facilitate evaporation of water from wet surfaces. In general, windows or doors throughout the unit should be opened periodically to provide ventilation.
4. Promptly clean up spills, condensation, and other sources of moisture. Thoroughly dry any wet surfaces or material. Do not let water pool or stand in your unit. Promptly replace any materials that cannot be thoroughly dried.
5. Inspect for leaks on a regular basis. Look for discolorations or wet spots. Repair any leaks promptly. Take notice of musty odors and any visible signs of mold growth.
6. In many cases, mold growth that develops on surfaces can be thoroughly cleaned with a mild detergent solution (other biocides and bleach solutions can be used, but should be handled with

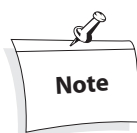

#### Note

If using a dehumidifier, please read and follow all manufacturer instructions and recommendations for use and cleaning.

caution) and dried completely. Porous materials with mold growth such as fabric, upholstery, or carpet should be discarded. Avoid exposing yourself or others to mold. A professional should be consulted if mold growth is extensive, a persistent musty odor is present, or evidence of ongoing water intrusion and dampness, leaks, unusual discoloration on walls or ceilings, or other concerns persist.

The information provided herein is merely a general guide to basic background information about mold and is not intended to be a complete discussion of possible problems relating to mold, methods for determining if a problem exists or of correcting mold problems. If you believe mold is present in your recreational vehicle you should immediately consult a qualified expert who will advise you on the proper steps for your specific situation.

### Use A Dehumidifier

During prolonged and continuous usage of the trailer, a dehumidifying appliance may be more comfortable and effective in removing excess moisture from interior air. While use of a dehumidifier is not a cure-all, operation of a dehumidifier will reduce the amount of outside air needed for ventilation. Thus, the heating load on the furnace will be reduced and the interior will be less drafty.



**WARNING**  
USE OF KEROSENE OR OTHER AFTERMARKET SPACE HEATERS IS NOT RECOMMENDED AND IS AT YOUR OWN RISK. SUCH HEATERS MAY DISCHARGE MOISTURE AND GASES FROM COMBUSTION INTO YOUR TRAILER OR CAUSE EXCESSIVE INDOOR HUMIDITY. SUCH HEATERS MAY ALSO CAUSE A FIRE, DEplete OXYGEN, OR RELEASE CARBON MONOXIDE OR OTHER HARMFUL GASES WHICH CAN CAUSE SERIOUS INJURY OR DEATH.

## Chapter 3: Towing and Leveling

### Your Travel Trailer — a True Recreational Vehicle

Your travel trailer is a vacation home on wheels. It is carefully designed for every normal recreational use and activity including travel. It is not designed or intended to be used as long-term or permanent, full-time housing. Long-term or full-time occupancy may lead to premature deterioration and may, under the terms of the warranty, constitute misuse and reduce your warranty protection.

Please refer to page 7 of this manual and review the section relating to ventilation and condensation problems that may occur due to long-term occupancy.

Skyline strongly recommends that your recreational vehicle not be occupied while traveling. It is unsafe and illegal to ride in a travel trailer in all states and it is illegal to ride in a fifth wheel in most states. Your recreational vehicle is not equipped with seat belts or other highway safety provisions commonly required for passenger vehicles. Also in some emergency conditions cargo could shift suddenly resulting in injury or even death.

### Do's and Don'ts For Equipment Selection

- Be sure the tow vehicle is large enough for your trailer or fifth wheel and has the needed power and heavy duty running gear. It must be rated by its manufacturer to tow the gross weight, and to carry the hitch weight of the fully loaded trailer or fifth wheel.
- Use a weight distributing hitch rated not less than the trailer Gross Vehicle Weight Rating (GVWR). Follow the tow vehicle and hitch manufacturers' instructions. Install the hitch ball as close as practical to the rear bumper to minimize rear overhang. (Does not apply to fifth wheels.)
- Do not overtighten the weight distributing hitch spring bars. Follow the instructions of the hitch manufacturer. When in doubt, use the less tight spring bar setting. (Does not apply to fifth wheels.)
- Use a sway control system. Install and adjust according to the instructions of the sway control manufacturer. (Does not apply to fifth wheels.)



**WARNING**  
NEVER RIDE IN YOUR RECREATIONAL VEHICLE.

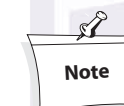

**Note**  
Passengers are not permitted in the recreational vehicle while it is in motion.

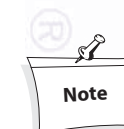

**Note**  
Heavy duty commercial vehicles larger than one ton may be used as a tow vehicle only if an energy absorbing hitch, such as the Air Ride Hitch™, is used to couple the recreational vehicle to the tow vehicle. The rough ride of the larger trucks can cause structural problems to develop in recreational vehicles if an energy absorbing hitch is not utilized.

- Do not add any type of adapter to the fifth wheel king pin, such as a goose neck adapter. Lengthening the fifth wheel hitch by means of an adapter will transfer greater loads to the chassis, possibly more than the chassis is designed for, and could result in structural damage. Damage that is a direct result of the use of such an adapter is not covered by Skyline warranty.
- Use a brake controller that automatically applies the brakes in proportion to the tow vehicle brakes and also has a hand control for applying the trailer brakes only.
- Adjust the brake controller so that the brakes of the trailer come on as quickly as possible without sliding the tires of the loaded trailer during strong braking.
- Inflate the rear tires of the tow vehicle to their maximum cold pressure. (See the maximum pressure rating on the rear tire sidewalls.)
- Load heavy objects and goods as close to the trailer axle(s) as possible. Do not place heavy objects on the rear bumper or on the tongue.

Your trailer may be equipped with an optional spare tire mounted on the bumper. The bumper is designed only to carry the spare tire, approximately 65 pounds. If the trailer is not equipped with a spare, no load greater than 65 pounds shall be placed on the bumper.

## Towing Guidelines

Weight distribution is an important factor when loading your fifth wheel and travel trailer. A recreational vehicle with the cargo distributed properly will result in efficient, trouble-free towing. Loading the coach as evenly as possible and then weighing the loaded RV can accomplish proper weight distribution. Keep heavier items as low as possible and distribute evenly (front to back and side to side). Securing your possessions can prevent damage from shifting during towing and maintain the weight distribution balance achieved during preparation for travel.

You must not exceed the GVWR or GAWR of the unit (see definitions). To verify GVWR, total the loaded hitch and axle weights. If this total exceeds GVWR, you must remove items until the vehicle weight is within this limit. You can verify that the coach's axles are not overloaded by comparing the loaded axle weight with the GAWR. If the reading is above this limit, redistribute the item load.

Finally, make sure the pin weight of the loaded fifth wheel falls within the limits of the tow vehicle.

## Weight Ratings - Definitions

### **GVWR (Gross Vehicle Weight Rating)**

The maximum permissible weight of this coach when fully loaded. It includes all weight at the unit's axle(s) and tongue or pin.

### **UVW (Unloaded Vehicle Weight)**

The weight of this trailer as manufactured at the factory. It includes all weight at the trailer axle(s) and tongue or pin. If applicable, it also includes full generator fluids, fuel, engine oil and coolants. The UVW does not include cargo, fresh water, full propane tanks, or dealer installed accessories.

### **CCC (Cargo Carrying Capacity)**

Is equal to GVWR minus each of the following: UVW and full fresh (potable) water weight (including water heater).

### **GAWR (Gross Axle Weight Rating)**

The maximum allowable weight that an axle system is designed to carry, as measured at the tire/ground interfaces.

## Weight Rating - Labels

The information on the weight ratings is contained on two labels: The Federal Certification Tag and the RV Trailer Cargo Carrying Capacity Label. Each label contains the Vehicle Identification Number (VIN) / Serial Number for the vehicle rated. These ratings are specific for each fifth wheel and travel trailer manufactured. Use only the ratings found on these labels.

## Federal Certification Label

MANUFACTURED BY:			DATE:		
GVWR	KG(	LB)			
GAWR ALL	KG(	LB) PER AXLE WITH	TIRE	RIM	
AT	KPA(	PSI) COLD SINGLE			
THIS VEHICLE CONFORMS TO ALL APPLICABLE US FEDERAL MOTOR VEHICLE SAFETY STANDARDS IN EFFECT ON THE DATE OF MANUFACTURE SHOWN ABOVE					
VIN:	TYPE:	MODEL:			

### Location

The Federal Certification Tag on your fifth wheel or travel trailer can be located on the road side (off-door side) near the front of the unit as seen in the diagrams below. This tag contains the GVWR, GAWR (front and rear) and tire pressure limits.

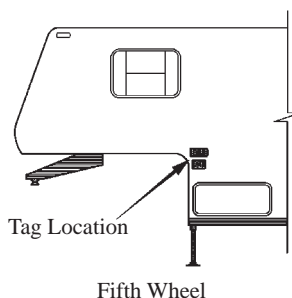
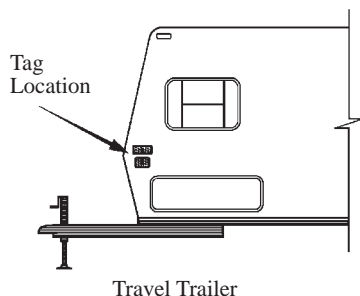

## RV Trailer Cargo Carrying Capacity Label

RECREATIONAL VEHICLE TRAILER CARGO CARRYING CAPACITY  
VIN: # 1SE200L239C000259  
THE WEIGHT OF CARGO SHOULD NEVER EXCEED:  
911 kg OR 2,009 lbs  
CAUTION:  
A full load of water equals 136 kg OR 299 lbs of cargo @ 1 kg/L (8.3 lb/gal)

### Location

The label is required to be on the interior of the curb-side entry door closest to the front of the vehicle. Vehicles having only a rear door will have the label on the inside of this door. The label is positioned on interior side of the screen door, about the center of the top rail above the screen mesh.

This label identifies the cargo carrying capacity after considering all manufacturer installed equipment and full propane tanks. This is the maximum amount of cargo you can add to this vehicle. The label also lists the maximum weight of fresh water the vehicle is designed to carry in the fresh water system. The weight of water added to the fresh water system must be included as part of the cargo. For example, if label indicates the weight of cargo should never exceed 2,009 pounds and a full load of water equals 299 pounds, this means you can add 1,710 pounds of cargo and fill the water system to capacity or empty the water system and add 2,009 pounds of cargo. We strongly recommend weighing your loaded RV prior to travel as described in this manual beginning on page 15 to ascertain you are within all weight limitations.

### RV Trailer Cargo Carrying Capacity Modification Label

CAUTION: LOAD CARRYING CAPACITY REDUCED  
Modifications to this vehicle have reduced the original load carrying capacity by  
\_\_\_ kg or \_\_\_ lbs

This label may be installed by your dealer if additional equipment was added at the dealership that significantly affected the cargo carrying capacity of your vehicle (the lesser of 1.5% of GVWR or 100 pounds). If equipment was added by the dealer this label will be located adjacent to the label described above. Alternatively, the dealer may have installed a new RV Trailer Cargo Carrying Capacity Label or modified the original label installed by Skyline. If your unit has one of these labels, the weight listed on the modification label must be subtracted from the weight on the RV Trailer Cargo Capacity Label to determine the new cargo carrying capacity with the dealer added accessories.





## Steps for Determining Correct Load Limit

1. Locate the cargo carrying capacity on the RV Trailer Cargo Carrying Capacity Label. (See Page 13)
2. This figure equals the available amount of cargo, luggage, and fresh water load capacity.
3. Determine the combined weight of luggage and cargo being loaded on the vehicle. If you plan to fill the fresh water system add the weight of the water, also found on the RV Trailer Cargo Carrying Capacity Label. The total of these weights must not exceed the available cargo and luggage load capacity.

For trailers with living quarters installed, the weight of water also needs to be considered. The weight of fully filled propane containers is considered part of the weight of the trailer before it is loaded with cargo, and is not considered part of the disposable cargo load. Water, however, is a disposable cargo weight and is treated as such. If there is a fresh water storage tank of 100 gallons, this tank when filled would weigh about 800 pounds. If more cargo is being transported, water can be off-loaded to keep the total amount of cargo added to the vehicle within the limits of the GVWR so as not to overload the vehicle. Understanding this flexibility will allow you, the owner, to make choices that fit your travel needs.

When loading your cargo, be sure it is distributed evenly to prevent overloading front to back and side to side. Heavy items should be placed low and as close to the axle positions as reasonable. Too many items on one side may overload a tire.

All objects should be held securely in place. Loose items can cause interior damage and erratic trailer movements. They can even be a hazard to others if they fall out. Load shifts can affect driving and handling enough to cause serious, unexpected danger. Inspect tie-downs and fastenings, as well as the load, at regular intervals every hour or two, depending on roads, curves, hills, and speed. The first check should be made within a half hour after the trip is started or after the first 25 miles, since some initial settling is likely.

If you are going on a long trip, take a “shakedown cruise” of a few miles the weekend before you leave. This will test your load, safety equipment, hitch, and might reveal things you missed or forgot. By getting everything in order before you leave home, you can prevent delays and annoyances that could take the fun out of your trip.

Many owners place luggage, camping equipment, bicycles, and other items in the travel trailer. The weight of everything put on or in a trailer, whether temporarily or permanently built-in, must be included in figuring the total load.

## How Overloading Affects Your RV and Tires

The results of overloading can have serious consequences for passenger safety. Too much weight on your vehicle's suspension system can cause spring, shock absorber, or brake failure, handling or steering problems, irregular tire wear, tire failure or other damage.

If insufficient weight is placed on the hitch, the trailer will tend to move from side to side, or to “fishtail”, which can be dangerous. Towed trailers are designed to have proper weight on the hitch for balance when the trailer floor is level.

An overloaded vehicle is hard to drive and hard to stop. In cases of serious overloading, brakes can fail completely, particularly on steep hills. The load a tire will carry safely is a combination of the size of tire, its load range, and corresponding inflation pressure.

It is the air pressure that enables a tire to support the load, so proper inflation is critical. To illustrate the importance of proper tire inflation and how inflation affects load limits, a trailer with four 225/75-D tires with 65 psi. of cold inflation pressure can carry a total of 10,160 pounds assuming the weight is evenly distributed between the four tires. The same four tires at 55 psi of cold inflation pressure can carry only 9,080 pounds. A reduction of 1,080 pounds! If the actual load on the tires is 9,500 pounds the need for full inflation pressure is obvious. Under-inflated tires can show excessive signs of wear, cause reduced handling capability, overheat, suffer belt separation or fail completely.

Tires should never be inflated beyond the maximum cold inflation pressure molded into the sidewall of the tire. See chapter 10 for additional information.

### WARNING

WHILE CARGO CAN BE ADDED UP TO THE MAXIMUM CARGO CARRYING CAPACITY, CARE MUST ALSO BE EXERCISED TO NEVER EXCEED THE GAWR, GVWR, NOR THE MAXIMUM LOAD RATINGS FOR YOUR VEHICLE OR HITCH.

### WARNING

OVERLOADING OR IMBALANCED LOADING OF YOUR TRAVEL TRAILER CAN AFFECT HANDLING OR CAUSE AN ACCIDENT THAT COULD RESULT IN SERIOUS INJURY OR DEATH.

### WARNING

EXCESSIVE LOADS AND/OR UNDERINFLATION CAUSE TIRE OVERLOADING AND, AS A RESULT, ABNORMAL TIRE FLEXING OCCURS. THIS SITUATION CAN GENERATE AN EXCESSIVE AMOUNT OF HEAT WITHIN THE TIRE. EXCESSIVE HEAT MAY LEAD TO TIRE FAILURE.

### DANGER

WHEEL SEPARATION CAN OCCUR! EXCEEDING THE GVWR AND GAWR RATINGS FOR YOUR UNIT COULD RESULT IN SERIOUS DAMAGE TO THE SUSPENSION, FRAME OR OTHER COMPONENTS.

## Weighing Your Unit

The total weight, including liquids, groceries, clothing, etc. must not exceed the Gross Vehicle Weight Rating (GVWR) stated on the Federal Certification Label on your Trailer. The total load on the front and rear wheels must not exceed the respective Gross Axle Weight Rating (GAWR) shown on the label.

### Travel Trailer

- Drive the loaded trailer onto the scales as shown in (Figure A) the picture below, making sure that the hitch will be the only contact point with the scales after unhooking. Unhook and drive the tow vehicle off the scales. Level the trailer and record hitch weight.
- Hookup to the trailer and pull forward on the scales until only the trailer axles are on the scale (Figure B). Record the axle weight.
- To determine total trailer weight, add the hitch weight plus axles.

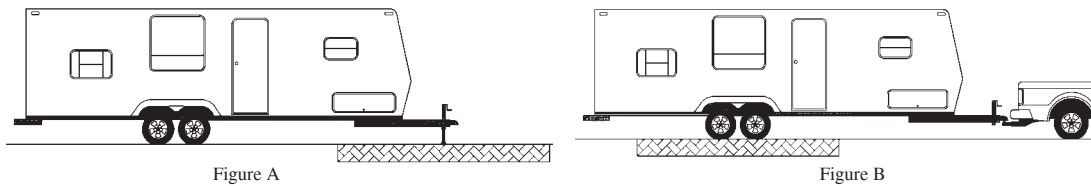

1. The total trailer weight (dry weight of standard unit plus options added plus water stored plus liquid wastes in holding tanks plus all cargo) must not exceed the GVWR stated on the label of your trailer.
2. The total load of your fully loaded trailer on the tires when connected to the towing vehicle must not exceed the combined total Gross Axle Weight Rating (GAWR). The GAWR is stated on the Federal Certification Label.
3. The hitch weight must not exceed your hitch manufacturer's recommendation. It should be 10 to 15 percent of the total travel trailer weight. (Hitch weights as low as 8% may be acceptable on some small, lighter weight models)
4. Equalize side to side loading. Store heavy objects on or near the floor.
5. Avoid towing with waste holding tank(s) full or partially full. If unavoidable, drive slowly until one or both tanks can be dumped.
6. Keep water tank either completely full or empty when towing to avoid the shifting of weight of a partially filled tank.

### Fifth Wheel

- Pull onto the scales until all tow vehicle tires are on the scale, but not the fifth wheel. Record this weight (vehicle + pin weight of fifth wheel).
- Pull forward until only the fifth wheel tires are on the scale. Record the axle weight.
- Pull off the scales, un-hook the fifth wheel and weigh the truck by itself.

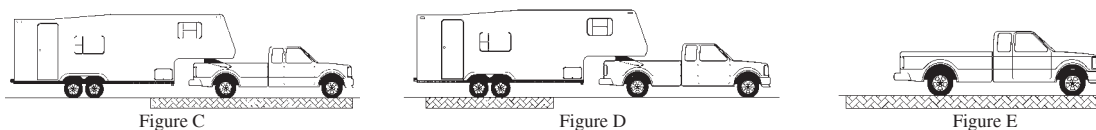

1. The total load on the fifth wheel tires when connected to the towing vehicle must not exceed the combined total Gross Axle Weight Rating (GAWR). The GAWR is stated on the Federal Certification Label. Pull onto the scale such that only the fifth wheel axles are on the scale (Figure D). Record the axle weight.
2. Calculate the pin load by subtracting the weight of the truck (figure E) from the weight of the truck with fifth wheel attached (Figure C). The pin weight thus obtained should be 19% - 25% of the total fifth wheel weight for good towing. The pin weight must not exceed the maximum allowable for your truck. (Consult truck manufacturer's specifications for your vehicle).

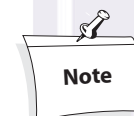

#### Note

Use a fifth wheel hitch for a two-inch SAEJ 700 king pin; an Atwood (or equivalent) 25,000 pound 2-5/16 inch diameter folding ball plate for units factory equipped with the Atwood 25,000 pound GVW gooseneck coupler; and a truck capable of towing the trailer GVWR.

**WARNING**

OUTSIDE STORAGE COMPARTMENTS ARE NOT SEALED. THEY ARE VENTED ENCLOSURES, AND ARE ACCESSIBLE FROM INSIDE THE TRAILER. THEREFORE, DO NOT STORE FLAMMABLE, VOLATILE LIQUIDS, HAZARDOUS CHEMICALS OR EQUIPMENT IN THESE AREAS.

**WARNING**

ONLY TRAILERS CONSISTING OF BOTH A DOOR (WIDTH GREATER THAN 36 INCHES) AND AN ACCESS RAMP ARE CAPABLE OF TRANSPORTING OR STORING MOTORIZED VEHICLES OR EQUIPMENT.

**DANGER**

ANY MOTORIZED VEHICLE OR ANY MOTORIZED EQUIPMENT POWERED WITH FLAMMABLE LIQUID CAN CAUSE FIRE, EXPLOSION, OR ASPHYXIATION IF STORED OR TRANSPORTED WITHIN THE RECREATIONAL VEHICLE.

**DANGER**

FAILURE TO COMPLY COULD RESULT IN AN INCREASED RISK OF FIRE, EXPLOSION OR ASPHYXIATION.

**DANGER**

ANY MOTORIZED VEHICLE OR ANY MOTORIZED EQUIPMENT POWERED WITH FLAMMABLE LIQUID CAN CAUSE FIRE, EXPLOSION, OR ASPHYXIATION IF STORED OR TRANSPORTED WITHIN THE RECREATIONAL VEHICLE. TO REDUCE THE RISK OF FIRE, EXPLOSION, OR ASPHYXIATION:

1. DO NOT RIDE IN THE VEHICLE STORAGE AREA WHILE VEHICLES ARE PRESENT.
2. DO NOT SLEEP IN THE VEHICLE STORAGE AREA WHILE VEHICLES ARE PRESENT.
3. CLOSE DOORS AND WINDOWS IN WALLS OF SEPARATION (IF INSTALLED) WHILE ANY VEHICLE IS PRESENT.
4. RUN FUEL OUT OF ENGINES OF STORED VEHICLES AFTER SHUTTING OFF FUEL AT THE TANK.
5. DO NOT STORE, TRANSPORT OR DISPENSE FUEL INSIDE THIS VEHICLE.
6. OPEN THE WINDOWS, OPENINGS, OR AIR VENTILATION SYSTEMS PROVIDED FOR VENTILATING THE TRANSPORTATION AREA WHEN VEHICLES ARE PRESENT.
7. DO NOT OPERATE PROPANE APPLIANCES, PILOT LIGHTS, OR ELECTRICAL EQUIPMENT WHEN VEHICLES ARE PRESENT.

FAILURE TO COMPLY COULD RESULT IN AN INCREASED RISK OF FIRE, EXPLOSION, ASPHYXIATION, DEATH OR SERIOUS INJURY.

3. Calculate total weight by adding pin weight obtained in step two to axle weight from step one. This total must not exceed the GVWR stated on the Federal Certification Label.
4. As a final precaution, if possible, with the fifth wheel connected to the tow vehicle pull forward across the scale until only the rear tires of the truck are on the scale (Figure F). This load must not exceed the rear axle weight rating (RAWR) on the Federal Certification Level of your truck.

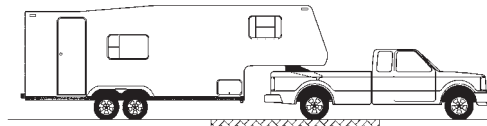

Figure F

See your dealer if you have any questions on these rules and other towing tips.

These procedures should be repeated whenever there is any change in vehicles or loading to ensure that you do not exceed the ratings.

## Storage

The storage facilities in your trailer have been designed to remain secure while in motion. Exterior compartments have key operated locks. Drawers rest in small notches or dents when closed; to open lift slightly to clear the dent, then pull open. When storing articles:

- Always keep tools and equipment stored in areas where they will not shift while traveling.
- Wherever possible, place heavy articles in storage compartments which are low and near the axles for better weight distribution.
- Pack articles carefully in the storage compartments to minimize shifting. If necessary, use straps to prevent movement.
- Be sure liquid containers are capped and cannot tip or spill. Secure all glass containers and dishes before traveling.
- Secure all free standing furniture.
- Exterior storage compartments may not be watertight in all climate conditions. Carry any articles which could be damaged by water inside the trailer.

## Special Transportation Provisions

If your recreational vehicle has been equipped with an entrance door greater than 36 inches in width and an access ramp for that door, only then can your recreational vehicle be used to store motorized vehicles or equipment.

The following steps should be taken to aid in reducing the risks associated with transporting, storing, or cohabitation with motorized equipment and vehicles:

1. Do not allow passengers to ride inside the vehicle storage area while vehicles are present.
2. Do not sleep in the vehicle storage area while vehicles are present.
3. Doors and windows in walls of separation are to be closed while the vehicles are present.
4. Run fuel out of engine of stored vehicles after shutting off fuel at the tank.
5. Do not store or transport motor fuel inside this vehicle.
6. Ventilate the interior of the trailer to reduce the risk of fire, explosion, or asphyxiation.
7. Do not operate gas appliances, pilot lights, or electrical equipment when motorized vehicles or motorized equipment are inside the vehicle.
8. Load and store your motorized vehicles and equipment according to the trailer loading and trailer storage sections in this manual.
9. During transit, secure motorized vehicles and motorized equipment so that items do not move while in transit.

10. Remove carpet from section where fueled vehicles or motorized equipment will be stored.  
Note: Carpet must be removed from cargo area prior to loading or securing vehicles for transport.
11. Disconnect 12-volt and 120-volt wiring when transporting motorized equipment by use of the 12-volt cutoff switch and 120-volt circuit breakers.

## Hitches and Towing

Hitching your trailer to the tow vehicle will become routine with experience. Make it a habit to examine all hitch components before hitching the trailer. If you have a conventional ball hitch, check for cracked or bent parts, cracked welds, deformed or stripped bolts. Inspect the spring bars and chains. Be sure the ball is tight and well lubricated. Check the trailer tongue for cracks. Be sure the ball locking device works freely. Inspect the safety chains. If you find a defect in any hitch component, correct it before towing the trailer.

If you have a fifth wheel trailer, check all truck-mounted hitch components. Check for worn, cracked, or bent parts. Be sure the locking device works properly. Inspect the pin box assembly on the trailer. Check the king pin. If you find any defective components, repair or replace them before towing. Be sure all moving parts of the hitch are well lubricated.

### Fifth Wheel

1. Adjust the landing gear jacks until coach is at a level for hooking to the tow vehicle.
2. Place wheel chocks behind fifth wheel's tires.
3. Lower the tailgate on truck.
4. Release the fifth wheel lock handle on the tow vehicle.
5. Line up the tow vehicle so the fifth wheel will accept the kingpin.
6. Check clearances. You may need to close truck tail gate, when far enough past kingpin to do so, prior to fully engaging fifth wheel hitch.
7. Back truck slowly until kingpin engages the fifth wheel and automatically locks.
8. Ensure the lock is closed, and locked in closed position.
9. Connect the power seven-way cord between the tow vehicle and the fifth wheel.
10. Connect the emergency breakaway switch cable.
11. Test the fifth wheel brakes and exterior running lights, stop lights and turn lights. With jacks still down, apply trailer brakes and try to pull forward slowly. The trailer brakes should keep the truck from moving forward if hitch is locked correctly.
12. Completely raise the landing gear.
13. Remove and store the wheel chocks.
14. Check the tire pressure while the vehicle tires are cold.
15. Re-torque the lug nuts. Refer to "Wheel Nut Torque".

### Travel Trailers

Before attempting to hitch up your trailer, read the instructions provided by the manufacturer of the hitch. Some Skyline trailers accept a 2-inch ball, while others accept a 2-5/16 inch ball. The following instructions apply in most cases. If the instructions provided with your hitch are different from these instructions, follow those of the hitch manufacturer:

1. Place wheel chocks behind the travel trailers tires.
2. Turn the tongue jack crank clockwise. This will raise the tongue and coupler. Raise the tongue sufficiently to clear the hitch ball on the tow vehicle.



**IT IS NOT SAFE COHABITING IN THE INTERNAL COMBUSTION ENGINE VEHICLE STORAGE AREA WHILE VEHICLES ARE PRESENT. FAILURE TO FOLLOW THESE IMPORTANT PRECAUTIONS MAY RESULT IN SERIOUS INJURY OR DEATH.**



**DO NOT EXCEED THE TRAILER GVWR WHEN LOADING YOUR TRAILER.**

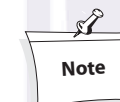

Skyline cannot provide instructions for securing every type of vehicle or equipment that might be transported. In many cases the vehicle manufacturer or selling dealer may be able to provide tie-down instructions. For most vehicles, it is imperative the front wheels be secured or blocked in such a manner that prevents them from turning or moving in any direction, in addition to tying down the rest of the vehicle. You are responsible to make sure the vehicles or equipment you transport is properly secured.



**DO NOT CONNECT THE BREAKAWAY SWITCH LANYARD TO ANY REMOVABLE PART OF THE HITCH.**

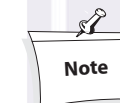

See electrical system section of this manual for details of the electrical system and wiring.



**WARNING**

**FOLLOW THE INSTRUCTIONS OF THE HITCH MANUFACTURER FOR ADJUSTING THE WEIGHT DISTRIBUTING HITCH. OVERTIGHTENING OF HITCH SPRING BARS WILL REDUCE CORNERING AND STOPPING ABILITY AS WELL AS TOWING STABILITY.**

**WARNING**

**NEVER ATTACH SAFETY CHAINS TO THE HITCH BALL OR ANY REMOVABLE PART OF THE HITCH.**

**WARNING**

**DO NOT CONNECT THE BREAKAWAY SWITCH LANYARD TO THE HITCH BALL OR ANY REMOVABLE PART OF THE HITCH.**

3. Back the tow vehicle until the hitch ball is under the hitch ball socket. If you are working alone, a backing aid mirror may be helpful. Set the parking brake.
4. The coupler latch locking lever on the tongue should be fully open. Lower the tongue jack until the ball is firmly seated in the socket. Close the coupler latch and secure it with a locking pin or bolt.
5. Raise the tow vehicle and trailer with the tongue jack high enough to allow room to install the hitch spring bars. (The tow vehicle will come up with it if the coupler is properly latched).
6. Attach the spring bars according to the hitch manufacturer's instructions.
7. After adjusting the spring bars, raise the jack off the ground to its highest level. Note that the trailer must be relatively level front to back. Tilt in either direction must be kept to an absolute minimum. Having the front lower than the rear reduces towing stability on tandem axle trailers.
8. Install the sway control system according to the manufacturer's instructions.
9. Connect all safety chains. Safety chains are extremely important to protect your investment as well as other people's lives and property. As a trailer owner, it is your responsibility to be familiar with these devices and their correct use. The hitch on your tow vehicle must be equipped with two chain attachment eyes, on each side of the vehicle's centerline. Install the chains by threading each one through its attachment eye and hooking it back on itself. Adjust each chain length so that it is as short as possible, but still permits full "jackknife" turns without becoming tight. Both chains should be the same length and crossed under the trailer's tongue to hold the tongue off the ground if the trailer accidentally becomes uncoupled.
10. Connect the emergency breakaway switch cable.
11. Plug in the 12-volt 7-way electrical connector.
12. Check stop lights, turn lights, running lights, and electric brakes before driving off. See ELECTRICAL SYSTEM section in this manual for details of the electrical system and wiring.
13. Remove and store the wheel chocks.
13. Reverse the procedure for unhitching, placing wheel chocks at the front and rear of the trailer tires prior to uncoupling the trailer from the tow vehicle to ensure the trailer does not roll away when the coupling is released.

## Before Towing

- Ensure the TV antenna is down and in the correct position.
- Disconnect and securely store all park connections.
- Close and secure all doors, windows, awnings and roof vents.
- Return the Entry step to the travel position.
- Refer to the "Pre-Travel Checklist" located in the Appendix.

## Towing

Towing a recreational vehicle can be enjoyable and worry-free if special attention toward safety is applied every time you hit the road. Before heading out on your first camping trip, practice turning, stopping and backing in low traffic areas or large parking lots. In time, traveling with a recreational vehicle in tow will be as easy as driving the family car.

## Before Heading Out

### Weight Distribution

Proper weight and load distribution is absolutely essential to safe towing. It is necessary to maintain a certain percentage of gross vehicle weight on the tow vehicle. Common recommendations place approximately 10% - 15% of a loaded weight on a travel trailer hitch and approximately 19% - 25% on a fifth wheel pin weight. Too much or too little weight upon the hitch leads to dangerous driving conditions such as sway and reduced tow vehicle control. In no circumstance should the loaded weight ever exceed the GVWR or the GAWRs.



## Safety Chains

Always use safety chains when towing. They maintain the connection between the travel trailer and tow vehicle in the event of separation of the ball and trailer coupling. Safety chains are included with every travel trailer and, in most states, are required when towing a travel trailer. Hook them to the frame of the tow vehicle (not the hitch), crossing them under the trailer's tongue. Inspect the length of the chains once attached to the tow vehicle frame. They should be long enough to allow for turns, but short enough to avoid any drag.

## Breakaway Switch

The breakaway switch is another safety device as it provides a means of automatically slowing and stopping your RV if it should become detached during traveling. The cable from the breakaway switch should be attached to the tow vehicle so that it remains connected in the event the trailer coupling detaches from the hitch ball. The breakaway switch is powered from the RV 12 Volt battery. If separation occurs the pin is pulled out of the switch and current from the RV battery is applied to the trailer brakes. See electrical section for testing breakaway switch.

## Tire Pressure

Maintaining proper tire pressure is another key to safety. The cold inflation pressure for each axle is located on the Federal Certification Label. Cold inflation pressure refers to the pressure in the tire prior to traveling. Always check your tire pressure before traveling. Underinflated tires will cause excessive sidewall flexing and produce extreme heat, leading to early tire failure and possible loss of control. Overinflated tires can cause uneven tire wear and also lead to early failure. More information on tires and maintenance can be found in the Care and Maintenance section.

- Most tires may naturally lose air over time, up to several PSI per month in some conditions.
- Tires can lose air suddenly if you drive over a pothole or other object or if you strike the curb when parking.
- With radial tires, it is usually not possible to determine underinflation by visual inspection.

## Level Towing

Having the tow vehicle and recreational vehicle level with each other will help improve towability as well as safe driving. A hitch that is too low can cause the front to drag. A hitch that is too high can cause the rear to hit those high spots in the road.

## Lights

Check all electrical connections to ensure all lights on the tow vehicle and travel trailer are functioning properly. The brake lights, hazards and turn signals should be in synchronization with the tow vehicle.

## Mirrors

Adjust the mirrors on the tow vehicle prior to departure. Having someone to assist you will make this safety step quick and easy. First line up the tow vehicle and trailer. Next, sit in the driver's seat and adjust the left mirror to where you can see the entire left side of the trailer and well beyond. Finally, while still sitting in the driver's seat, have someone adjust the right mirror until the same result is achieved.

## Tire Safety Tips (also see chapters 9&10)

### Preventing Tire Damage

- Slow down if you have to go over a pothole or other objects in the road.
- Do not run over curbs or other foreign objects in the roadway, and try not to strike the curb when parking.

### Tire Safety Checklist

- Check tire pressure regularly (at least once per month), including the spare.
- Inspect tires for uneven wear patterns on the tread, cracks, foreign objects, or other signs of wear or trauma.
- Remove bits of glass and foreign objects wedged in the tread.
- Make sure your tire valves have valve caps.



**WARNING**

**DISCONNECT THE UNIT FROM THE SEVEN-WAY TOW VEHICLE CORD PRIOR TO TESTING THE BREAKAWAY SWITCH. FAILURE TO DO SO MAY CAUSE DAMAGE TO THE BRAKE CONTROLLER.**



**CAUTION**

**Check tires for proper inflation and wheel lug torque to meet manufacturer's specifications.**

- Check tire pressure before going on a long trip.
- Do not overload your vehicle. Check the Tire Information and Loading Placard, Federal Certification Label or Owner's Manual for the maximum recommended load for the vehicle.
- Drivers should always obey posted speed limits and reduce speeds when necessary based on vehicle, road, weather and/ or traffic conditions.
- Vehicle speed, load and inflation pressures, all of which are within the control of the driver, are critical factors for the safe and enjoyable operation of any vehicle.
- The tire designation 'ST' is the tire specifically for use by the trailer industry. Industry standards indicate tires with the 'ST' designation are speed restricted to 65 MPH under normal inflation and load conditions unless a different speed restriction is indicated on the sidewall of the tire. Therefore Skyline recommends restricting your towing speed to a maximum of 65 MPH. NEVER EXCEED POSTED SPEED LIMITS.

## While Driving

Driving with a trailer in tow is different. Start out slowly, checking the traffic after signaling and being sure the road is clear. Accelerate slowly and evenly, checking the mirrors frequently as you move into the proper lane. Try to drive with an anticipation of problems that may occur way ahead and prepare for them, even though they may never happen. As a motorist sharing the road, you are taller, heavier, longer and require more time and distance to stop. Weather and road conditions will require adjustments to speed. Anticipate dips, gutters, and depressions in the road, slowing down well in advance. These are the hardest jolts of any kind on your vehicle, hitch, recreational vehicle and items stored inside the unit. Take dips and bumps slowly and be certain the trailer wheels have passed the point before accelerating.

### WARNING

**TOW AT MODERATE SPEEDS ALLOWING FOR ADVERSE HIGHWAY AND WIND CONDITIONS. INCREASED SPEED REDUCES TRAILER TOWING STABILITY, AND HANDLING AND STOPPING ABILITY.**

### WARNING

**DO NOT ATTEMPT TO STOP THE TRAILER SWAYING BY MAKING QUICK STEERING CHANGES, OR BY FORCEFULLY APPLYING THE TOW VEHICLE BRAKES.**

### Towing Speed

Reasonable speed is probably the greatest factor in safe and pleasant towing. Towing stability is increased and emergency stopping distances are reduced with a reduction in speed. Reduce your driving speed substantially while towing. Slow down for grades and turns. Towing stability is reduced downhill and around bends. With experience, you will develop the special driving skills needed for safe trailer towing.

### Stability in Towing

Speed, cargo weight distribution, and wind conditions are the principal factors affecting trailer towing stability. It is an indication of reduced stability if the trailer sways from side to side after quick course changes, in cross winds, or while being passed by trucks or buses.

If the trailer begins to sway strongly from side to side, make as little steering correction as possible while maintaining vehicle control. Oversteering to counter trailer sway will increase sway and cause loss of control. Reduce speed gradually by using the hand control on the brake controller. Forceful tow vehicle braking may increase trailer sway. Locking tow vehicle wheels will cause loss of control.

Stop as soon as possible after any sign of reduced stability. Make sure all tires are fully inflated, the sway control is properly adjusted, and the hitch bars are adjusted according to the hitch manufacturer's instructions. Check for mechanical failures. If cargo is not properly loaded, shift some weight forward in the trailer. If you can't stop immediately, reduce speed until control can be maintained.

Heavy cross winds, particularly gusts in canyons or at other exposed locations, can cause excessive trailer swaying or loss of control. Under these conditions, reduce speed to maintain control.

Small but sudden course changes can occur when a vehicle towing a trailer is passed by a large flat-fronted vehicle such as a truck or bus. This happens when the side wind from the flat front of the truck blows against the side of the trailer. As the truck's front passes the rear of the trailer, the tow vehicle will tend to turn away from the truck; as the truck's front passes the trailer wheels, the tow vehicle will turn back toward the truck.

When a large flat-fronted vehicle passing from behind causes your vehicle to change course, make as little steering correction as possible. The tow vehicle will be turned back toward its original course as soon as the truck's front passes the trailer wheels. Avoid quick steering corrections that can magnify these course changes and start trailer swaying.

**Backing**

Place your hand at the bottom of the steering wheel. To turn the trailer to the left, move your hand to the left, turning the steering wheel clockwise. To turn the trailer to the right, move your hand to the right, turning the steering wheel counterclockwise. Your tow vehicle should go the opposite way that you want the trailer to turn. In time, and with a little practice, you will be able to back your trailer with little effort. Always be aware that you have poor visibility to the rear. Have someone stand outside at the rear of the trailer to guide you.

**Braking**

Start sooner and lead with your trailer brakes. Prior to beginning any trip, make sure the brake control is adjusted. See your accompanying literature for the brake control you purchased for your tow vehicle.

**Brake Inspection**

Inspect all external braking system components before moving your trailer. Also, inspect all wiring connections, and test the breakaway switch as outlined above. Inspect the brake drums and internal components each time the wheel bearings are lubricated. (See MAINTENANCE CHART at the back of this manual.) The magnets and linings should not show excessive or uneven wear. The magnets should move freely in and out on their mounts. After replacing the hubs on the axle, adjust the brakes as outlined below.

**Brake Adjustment**

Brakes should be adjusted after the first 200 miles of operation and every 3,000 miles thereafter. Adjust the brakes as follows using a standard automotive brake tool:

1. Remove the rubber plug from the adjustment hole at the base of the brake drum backing plate.
2. Raise the wheel off the ground. Place the jack under the axle only.
3. With the adjusting tool, turn the adjusting screw while spinning the wheel. When the wheel begins to drag heavily, back off the screw just enough for the wheel to spin freely.
4. Replace the adjustment hole plug. Lower the wheel, remove the jack, and repeat the sequence for the other wheels.

**Braking Tips**

1. Never use the trailer brakes alone for extended periods. They were designed to stop the trailer, not the tow vehicle. Such use places excessive loads on the brakes causing overheating, fading, and premature wear of magnets, brake shoe linings, and drums.
2. Never use the tow vehicle brakes alone. The added weight of your trailer more than doubles the load placed on the vehicle's brakes, with the same results as using trailer brakes alone. Driving control is also severely affected when tow vehicle brakes are used alone, due to the force of the trailer pushing against the tow vehicle. This is especially true on slippery pavement or loose gravel, and "jackknifing" can occur.
3. Always use the automatic brake controller. The synchronized braking system enables you to drive in a safe manner with both hands on the steering wheel. If the brake controller is properly adjusted, there will be a slight "lead" on the trailer brakes. This braking resistance, combined with the tow vehicle's engine pulling power, will help keep the two vehicles correctly aligned and help bring them to a safe, straight stop.

**Passing and Accelerating**

Remember when you pass another vehicle that it takes longer to accelerate and additional time must be allowed due to the added length of the trailer. Passing should be done on level terrain and downshift, if necessary for added acceleration. Whenever deciding to pass another vehicle, exercise caution and always use the turn signals. Once past the other vehicle, allow clearance using outside rear view mirrors for the trailer before returning to the original lane.

**Sharply Winding and Narrow Roads**

Keep well to the center of the lane, equally away from both the center line and pavement edge. This allows the trailer to clear the edge of the pavement without the likelihood of the wheels dropping onto the shoulder, causing potential dangerous sway. Do not overcrowd or cross the center line.

All sharp turns should be taken at low speeds. Professional drivers, when rounding turns, slow down well in advance of the turn, entering it at reduced speed, and then accelerate smoothly as they come out again into the straightaway.

 **DANGER**

SOME PROCEDURES REQUIRE THE USE OF SPECIAL TOOLS FOR SAFE AND CORRECT MAINTENANCE. DO NOT ATTEMPT TO SERVICE, REPAIR OR WORK ON ANY AXLE, BRAKE, OR WHEEL SYSTEM UNLESS YOU HAVE APPROPRIATE SKILLS AND KNOWLEDGE. LACK OF PROPER TRAINING, FAILURE TO FOLLOW PROCEDURES OR USE SPECIAL TOOLS AND SAFETY EQUIPMENT COULD RESULT IN PROPERTY DAMAGE, SERIOUS INJURY OR LOSS OF LIFE.

**Note**

Due to slower speeds, cars can become trapped behind you on a two-lane road. It is courteous and practical to signal and pull onto the shoulder when possible allowing them to pass. This reduces passing hazards and saves tempers.



Never leave brakes on for extended periods of time or they may over-heat.



Some tow vehicles have specifically calibrated transmission tow modes. Be sure to use the tow mode recommended by the manufacturer.

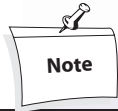

If the vehicle is parked on a grade, don't shift the transmission into 'P' (PARK) until the trailer wheels are chocked and the parking brake is set. If you do, the weight of the vehicle and the trailer may put so much strain on the transmission that it will be hard to shift out of 'P' (PARK).

### **Steep or Long Grades**

Down shifting into a lower gear or range in advance assists braking on descents and adds power on the climb. Avoid situations that require excessive and prolonged use of the brakes. Apply and release brakes at short intervals to give them a chance to cool.

### **Slippery Pavement**

On slippery and icy pavement, reduce speed and drive slowly. Hydroplaning can occur with little water on the pavement. If skidding begins, remove your foot from the throttle and gently apply the trailer brakes only.

### **Freeways and Highways**

Try to pick the lane in which you want to move and stay in it, preferably keeping to the slower lane on the right.

### **Stopping**

The increased weight of the tow vehicle-trailer combination requires greater stopping distances. Maintain at least twice the normal following distance while towing your trailer. Avoid strong braking on turns and prolonged braking on downgrades.

### **Mirrors**

There are many types of outside mirrors that can be used on tow vehicles. Most states require mirrors extending on both sides of the tow vehicle to provide the driver a clear view when passing or being passed. Check specific requirements in the states where you will travel. Install mirrors as close to the driver as possible to provide the maximum field of view.

### **Turning Corners**

Here is where you find a basic difference when towing. The trailer wheels do not follow the path of your tow vehicle's wheels. The trailer will make a closer turn than the tow vehicle. Compensate by pulling further into the intersection so that the trailer will clear the curb or clear any parked vehicles along the road. Left turns require a wider than normal swing into the new lane of traffic to keep the trailer from edging into the opposing lane. Use the turn signals early to communicate to traffic behind and slow down well in advance.

### **Mud and Sand**

Let the momentum of the tow vehicle and trailer carry you through. Apply power gently and stay in the tracks of the previous vehicle. If stuck, tow the trailer and tow vehicle out together without unhitching.

### **Parking**

You should not park vehicles with trailers on a grade or hill. However, if you must park on a grade, follow these steps:

1. Apply the tow vehicle foot brake.
2. Have someone place wheel chocks under the trailer wheels.
3. When the wheel chocks are in place and the assistant is clear, release the brakes until the chocks absorb the load.
4. Apply the parking brake.
5. Shift the transmission to "P" (PARK, with automatic transmission) or low or reverse with manual transmissions.

When starting after being parked on a grade:

1. Apply the foot brake and hold.
2. Start engine in "P" (for automatic transmission).
3. Shift into gear and release the parking brake.
4. Release the foot brake and drive until the chocks are free.
5. Apply the foot brake and have someone remove the chocks.

## Travel Trailer Leveling Procedures

1. Choose a site that is as level as possible (Some sites are equipped with a prepared surface such as concrete or asphalt.) Ensure the ground is not soft and will support the weight of the trailer on the stabilizer jacks or other support devices.
2. Before uncoupling, level the trailer from side to side with suitable lengths of 2" x 6" wood blocks under the trailer wheels. Place the wood blocks on the ground forward of the wheels, and tow the trailer onto the blocks. Block the wheels to be sure the trailer cannot roll.
3. If front-to-back leveling is required, unhitch the trailer from the tow vehicle, install the jack pad and crank or run the front jack down. The front jack should always rest on the jack pad and if the ground or surface is soft, place a board under the jack pad. Disconnect the safety chains, the pigtail, and breakaway cable from the tow vehicle. Move the front jack up or down until the trailer is level.
4. Check the level of the trailer with a carpenter's level both crosswise and lengthwise on the trailer floor.
5. Lower stabilizer jacks, placing wood block under foot as necessary, until they make firm contact with ground — Do Not Overtighten or try to lift trailer except for small amount needed to level.
6. After stabilizing the trailer, be sure the trailer frame is not twisted, buckled, or stressed. Check that all doors and windows operate freely and do not bind.
7. Before resuming travel, be sure all stabilizers are removed or fully retracted.

## Fifth Wheel Leveling Procedures

1. Choose a site that is as level as possible (some sites are equipped with a prepared surface such as concrete or asphalt). Ensure the ground is not soft and will support the weight of the fifth wheel on the stabilizing jacks or other support devices.
2. Before uncoupling, level the fifth wheel from side to side with suitable lengths of 2" x 6" wood blocks under the coach's wheels and tow the unit onto the blocks. Block the wheels to be sure the fifth wheel cannot roll.
3. Lower the "quick drop" landing gear legs before extending the landing gear. The positioning of the "quick drop" legs will depend upon how level your campsite is from side to side and front to rear. The landing gear is then extended. It may be necessary to place a sturdy 2" x 6" wood block under the foot pads to support the landing gear on soft ground surfaces.
4. After stabilizing the unit, be sure the fifth wheel frame is not twisted, buckled or stressed. Check that all doors and windows operate freely and do not bind.
5. Before resuming travel, be sure the stabilizer jacks are fully retracted.

## Stabilizing Jacks

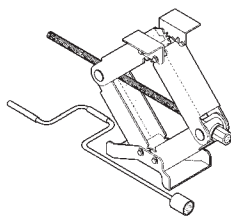

Scissor Jack

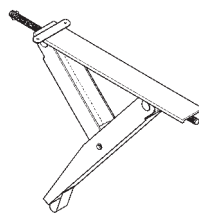

"T" Type Jack

Dependent upon the type (travel trailer/fifth wheel), product and model purchased, the stabilizer jacks included will vary. Although stabilizer jacks come in different types and sizes, all perform the same function: To stabilize the front and rear of all recreational vehicles while parked for camping.

Always park the recreational vehicle on level ground and use tire chocks. It is extremely important to level the trailer front and rear using the tongue jack (travel trailers) or landing gear (fifth wheels). Using the crank for the particular stabilizer jack, lower the jack(s) on the lowest side of the trailer first and check the level. Adjust if necessary and then lower the other jack(s) to finish stabilizing the trailer.

### CAUTION

Stabilizing jacks are designed to level and stabilize your coach. Do not attempt to lift the unit to change a tire or for any other purpose.

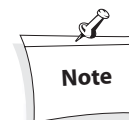

#### Note

After the trailer has been leveled side-to-side and front-to-back, you may wish to permanently attach levels on the front and/or back and sides of the RV. This will allow you to tell at a glance if you have parked on a level site and will help speed up the leveling process.

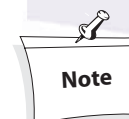

#### Note

**Leveling**  
Put a small round bubble-level inside the refrigerator to determine proper level for refrigerator operation.

**Slide-Outs**  
In extended use situations, it is advisable to add support blocks under the slide-room. Do not raise the room, just touch the bottom with the blocks.

### WARNING

AFTER-MARKET STABILIZER STANDS MUST BE PLACED ONLY UNDER CHASSIS FRAME RAILS. STABILIZER JACKS MUST NEVER BE PLACED AGAINST THE FLOOR. DO NOT ATTEMPT TO LEVEL, RAISE OR OTHERWISE PLACE ALL OF THE WEIGHT OF THE UNIT ON THE STABILIZER JACKS. DO NOT USE STABILIZER JACKS FOR TIRE CHANGING.



**WARNING**

SECURE CARGO AND VEHICLES AS FAR FORWARD AS POSSIBLE. EXCESS WEIGHT IN THE REAR OF TRAILERS CAN RESULT IN LOSS OF STABILITY WHEN TOWING.

CONSULT THE TRAILER OWNER'S MANUAL FOR LOADING AND WEIGHING PROCEDURES. KEEP THE LOADED TONGUE WEIGHT BETWEEN 10% AND 15% OF TOTAL WEIGHT FOR TRAVEL TRAILERS, AND BETWEEN 19% AND 25% OF TOTAL WEIGHT FOR 5TH WHEELS.

MOVE CARGO AND/OR VEHICLES TO MAINTAIN PROPER BALANCE. DO NOT EXCEED GVWR (TOTAL WEIGHT RATING) OR GAWRS (AXLE WEIGHT RATINGS) OF THE TRAILER OR TOW VEHICLE.

**DANGER**

PORTABLE FUEL-BURNING EQUIPMENT, INCLUDING WOOD AND CHARCOAL GRILLS AND STOVES, MUST NOT BE USED INSIDE THE RECREATIONAL VEHICLE. THE USE OF THIS EQUIPMENT INSIDE THE RECREATIONAL VEHICLE MAY CAUSE FIRES OR ASPHYXIATION.

**DANGER**

WHEN REFUELING TOW VEHICLE, SHUT OFF ALL PROPANE GAS APPLIANCES. MOST PROPANE GAS APPLIANCES ARE VENTED TO THE OUTSIDE. GASOLINE FUMES COULD ENTER THE APPLIANCE AND IGNITE FROM THE BURNER FLAME, CAUSING AN EXPLOSION OR FIRE.

**WARNING**

PROPANE CYLINDERS SHALL NOT BE PLACED OR STORED INSIDE THE VEHICLE. PROPANE CYLINDERS ARE EQUIPPED WITH SAFETY DEVICES THAT RELIEVE EXCESSIVE PRESSURE BY DISCHARGING PROPANE TO THE ATMOSPHERE.

FAILURE TO COMPLY COULD RESULT IN DEATH OR SERIOUS INJURY.

**WARNING**

DO NOT STORE OR USE GASOLINE OR OTHER FLAMMABLE VAPORS AND LIQUIDS IN THE VICINITY OF ANY APPLIANCE.

## Ramp Trailer Weight Distribution

All loaded trailers must remain within GVWR and GAWR limits. However, proper load distribution is of particular importance for ramp trailers. These trailers are designed to carry a variety of internal combustion engine vehicles in the transportation storage area. These cargo items are typically heavy and consideration must be given to how they are loaded. Because most storage areas are at the rear of the vehicle the biggest concern is maintaining the correct hitch or pin weight percentage. Vehicles loaded incorrectly can have too little weight resting on the hitch or pin and can become unstable when towing. Therefore, a hitch weight percentage of 10 - 15% for travel trailers and 19 - 25% for fifth wheels must be maintained. For example, if the loaded vehicle weighs 8000 pounds, the hitch weight for a travel trailer should be between 800 - 1200 pounds (10 - 15% of the 8000 pound total). For a fifth wheel this same 8000 pound vehicle should have a pin weight of 1520 - 2000 pounds (19 - 25%). By maintaining the correct hitch percentage and staying within the limits of the GVWR and GAWR you can insure a safe towing experience with your trailer. Never put carpet on cargo area floor prior to loading cargo or vehicles. Doing so would make it easier for cargo to shift during transit.

## Chapter 4: Appliances and Equipment

### What to do if you smell propane gas

1. Extinguish any open flames, pilot lights, and all smoking materials
2. Do not touch electrical switches
3. Shut off the propane supply container valve(s) or propane supply connection
4. Open doors and other ventilating openings
5. Leave the area until odor clears
6. Have the propane system checked and leakage source corrected before using again

FAILURE TO COMPLY COULD RESULT IN EXPLOSION RESULTING IN DEATH OR SERIOUS INJURY.

Refer to the individual manufacturer's owner's manual for operating instructions on the following equipment.

### Air Conditioner

The optional roof-mounted air conditioning unit can operate only when the trailer is connected to a 120-volt AC power source. Be sure that the air conditioner's circuit breaker is turned ON. For best performance, park the trailer in the shade and keep the curtains closed. Before operating any model of roof A/C, close all doors and windows. (The optional heat unit on some models is not a substitute for a primary heating system. It is designed to warm the air during moderately cool days or nights.)

Refer to the air conditioner manufacturer's instructions for detailed operation and preventive maintenance requirements. Remember that this appliance requires a large portion of your available electric power.

NOTE: Many units include dealer installed air conditioning units rather than factory installation. Check carefully to make sure there are no leaks around the air conditioning unit.

### Capability vs. Environment

The capability of the air conditioner to maintain the desired inside temperature is directly affected by the heat gain of the RV. During extreme high outdoor temperatures, the heat gain of the vehicle may be reduced by:

1. Parking in a shaded area
2. Keeping blinds down or drapes shut
3. Keeping windows and doors shut and minimize usage
4. Operating on High Fan/Cooling mode will provide the maximum efficiency in high humidity or high temperatures

5. Using awnings to block direct sunlight exposure on the unit
6. Avoiding use of heat producing appliances
7. Giving the A/C a “head start” by turning the air conditioner on early in the morning

**Care and Maintenance**

Periodically remove the return air filter and wash with hot soapy water. During extended use situations, cleaning is recommended after two weeks of daily usage.

**TV Antenna**

In many areas, television reception can be improved with an optional TV antenna. The TV antenna hookup includes an amplifying system, a coaxial connection for the antenna cable to your TV set, and an antenna crank for inside control. Some systems also have a 12-volt receptacle for TV sets designed to run on 12-volt DC power.

The cable connection, amplifying system switch and power ON indicator light are on a wall plate. Several different types of wall plates are used, so refer to the manufacturer’s instructions for details.

**To Raise Antenna**

1. Check location to ensure no obstacles will be encountered while raising the antenna.
2. Turn elevating crank (clockwise) in an “UP” direction about 13 turns or until resistance is felt.
3. Turn Power Supply switch to “ON” (If cable is being used the power supply switch needs to be set to “OFF”.)

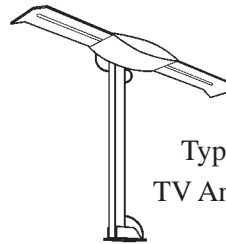
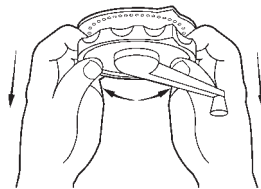
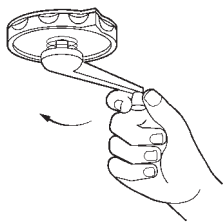

Typical TV Antenna

**Rotate for Best Picture**

1. Make sure antenna is fully raised.
2. Pull down on lower ceiling plate with both hands until it disengages and will turn.
3. Slowly rotate clockwise or counterclockwise for best picture and sound.

**To Lower Antenna**

1. Rotate antenna until pointer on directional handle aligns with pointer on ceiling plate.
2. Turn elevating crank (counterclockwise) in “DOWN” direction about 13 turns or until resistance is felt. Antenna is now locked in travel position.

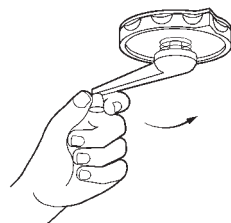

**Awning, Patio (Optional)**

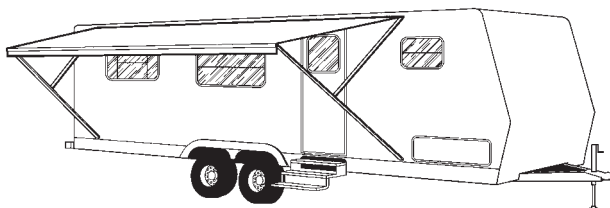

Never run the A/C without the filter. This could plug the unit evaporator cell, substantially affecting performance.



DO NOT RAISE TV ANTENNA NEAR OVERHEAD ELECTRICAL WIRES AS CONTACT MAY CAUSE INJURY OR DEATH.

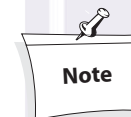

Always lower antenna before moving your unit.



If heavy rain or wind is predicted, or whenever you leave the awning unattended, it is best to close the awning. Damage to the awning or unit due to weather is not covered under the warranty.

**WARNING**

DO NOT ATTEMPT ANY REPAIRS TO THE AWNING. THE AWNING ROLLER TUBE IS UNDER EXTREME SPRING TENSION. REPAIRS SHOULD ONLY BE PERFORMED BY AN AUTHORIZED DEALER/REPAIR CENTER.

**WARNING**

DO NOT STORE COMBUSTIBLE MATERIAL IN FURNACE AREA.

FAILURE TO COMPLY COULD RESULT IN A FIRE OR PERSONAL INJURY.

**WARNING**

USE OF KEROSENE OR OTHER AFTERMARKET SPACE HEATERS IS NOT RECOMMENDED AND IT IS AT YOUR OWN RISK. SUCH HEATERS MAY DISCHARGE MOISTURE AND GASES FROM COMBUSTION INTO YOUR TRAVEL TRAILER AND CAUSE EXCESSIVE INDOOR HUMIDITY. SUCH HEATERS MAY ALSO CAUSE A FIRE, DEplete OXYGEN, OR RELEASE CARBON MONOXIDE OR OTHER HARMFUL GASES WHICH CAN CAUSE SERIOUS INJURY OR DEATH.

**DANGER**

FAILURE TO READ AND FOLLOW THE FURNACE USER'S INFORMATION MANUAL AND FOLLOW INSTRUCTIONS COULD CAUSE A FIRE OR EXPLOSION, CAUSING PROPERTY DAMAGE, SERIOUS INJURIES OR LOSS OF LIFE.

A patio awning is a very popular accessory on recreational vehicles. They provide additional living area for your campsite as well as protection. Skyline uses several awning models. The appropriate instructions for the equipped awning are included in the unit packet. Please review the manufacturer instructions carefully prior to using the patio awning.

**Care and Maintenance**

The best way to extend the life of the awning is to keep it clean and operating smoothly. At the start of every camping season or after extensive traveling, inspect the top and bottom brackets and tighten if loose. Moving parts, such as the lift handle, rafter and support arms, may become hard to operate due to weather exposure and use. If this occurs, spray the part(s) with a silicone spray. To keep the awning operation smooth, repeat the process on a regular basis. Mold and mildew on the fabric can be avoided by periodically cleaning the vinyl with a mild non-abrasive cleaner and inspecting it for leaves or other debris before closing. After cleaning, allow the fabric to dry completely before rolling up. When raining, lower one end of the awning so that the water will run off and not pool on the fabric, and avoid rolling it up when wet. If necessary, unroll as soon as conditions permit to allow the awning to dry.

**Cable Hook-Up**

At many commercial campgrounds, cable access is provided. To utilize the cable access, locate the exterior hookup on the side of the recreational vehicle. Attach cable to access hook-up and trailer hook-up. If your antenna inside control switch has a cable selection, move the sliding switch to cable. Otherwise turn to "OFF" position and hook TV coaxial cable into separate park cable jack.

**Converter: See Electrical Section**

**Fan-Tastic Vent™ (Optional)**

The Fan-Tastic Vent™ runs on 12V. Dependent upon the model, operational control may be by a wall control switch or by controls directly mounted on the vent. (See the information included in the unit packet for operating instructions concerning the installed model.) When using the Fan-Tastic Vent™, close all vents and slightly open the windows on a shaded side of the coach. The direction of the airflow is determined by which window(s) are opened. Please note that the dome of the vent must be opened at least three inches for the motor to operate. A safety switch will prevent operation if the dome is closed or open less than three inches.

**Furnace**

The furnace installed is a propane gas appliance. Carefully read the manufacturer's manual for complete operational and safety instructions, provided in the unit packet, prior to using the appliance.

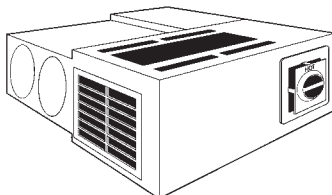

The furnace utilizes a sealed combustion system, which means the combustion chamber is completely sealed from the inner atmosphere of your vehicle. Combustion air is drawn from the outside and combustion products are expelled outside through a vent. The furnace is a forced-air system which pushes warm air throughout your travel trailer. The blower is wired to operate directly from your 12-volt or 120-volt system.

New furnaces sometimes emit smoke and an odor during the first 5 - 10 minutes of initial use due to machine oil burning off the heating chamber. Do not mistake this for a malfunctioning furnace. Opening windows and door prior to first lighting will help vent any smoke or odor.

IN CASE OF TROUBLE: Consult your furnace manufacturer's operation and service manual in your Owner's Kit for troubleshooting tips and information, and the location of your nearest service center.

**Thermostat - Wall Mounted**

Skyline travel trailers and fifth wheels have either a heat only thermostat or a combination air conditioner/furnace thermostat if an air conditioner is equipped at the factory. Once the furnace is on, its operation may be controlled entirely with the thermostat. You will not need to touch any of the other furnace switches or valves.

**Operation - Heat Only Thermostat**

To turn "ON": Set temperature to desired level.

To turn "OFF": Set thermostat to lowest setting and follow instructions for furnace operation in the manufacturer's user's guide.

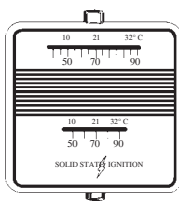

Typical Heat Only Thermostat

### Heat Operation - A/C Heat Thermostat

Set the temperature select lever to the desired temperature level. Set the system switch to “FURNACE”.

### Cooling Operation - A/C and Heat Thermostat

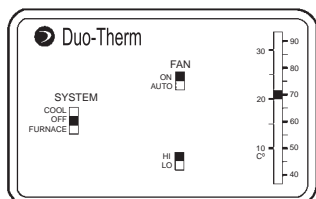

Heat/AC Thermostat

1. Set the temperature select lever to the desired temperature level.
2. Select the FAN speed.
3. “HI”: Maximum cooling/dehumidification.
4. “LO”: Maintaining temperature level/night use.
5. Select FAN AUTO/ON switch.
6. “AUTO”: Runs whenever cooling required and stops when not required.
7. “ON”: Air conditioner fan runs continuously to circulate air.
8. Set the system switch to the “COOL” position.
9. When the SYSTEM switch is in the “OFF” or “FURNACE” and the “AUTO/ON” switch is in the “ON” position; the A/C fan will run continuously at the selected fan speed. This circulates air inside the RV.

### Fueling Station (Optional)

Some sport utility models are equipped with an optional fueling station that can be used for fueling small motorized vehicles. Please observe the following precautions when using the fueling station:

- Review all warnings in the Generator section of this manual for gasoline generators. The same warnings apply to the use of this fueling station. Failure to follow them could result in serious injury and even death.
- All parts of the fuel transfer system including but not limited to the hoses, pump, nozzle, fittings, and tank have been selected for their quality, safety, and intended application. Any alteration or replacement of any part other than Skyline Corporation parts could jeopardize the integrity of the system and may result in serious injury or even death.
- If your fueling system is not working properly or you need additional information on the use of the system contact your authorized Skyline dealer immediately or call Skyline directly using the information in the front of this manual.
- Do not operate the pump for more than five (5) minutes with the nozzle closed.
- Do not operate the pump continuously for more than thirty (30) minutes in a one hour period.
- Do not operate the pump when the tank is empty.



**⚠ DANGER**

**NO SMOKING.**

**BEFORE DISPENSING FUEL, TURN OFF ALL ENGINES, FUEL-BURNING APPLIANCES, AND THEIR IGNITORS.**

**CONNECT THE BONDING JUMPER WIRE TO THE VEHICLE RECEIVING FUEL.**

**DO NOT DISPENSE FUEL WITHIN 20 FEET OF AN IGNITION SOURCE.**

**FAILURE TO COMPLY COULD RESULT IN FIRE, DEATH, OR SERIOUS INJURY.**

**⚠ DANGER**

**ALL PILOT LIGHTS, APPLIANCES, AND THEIR IGNITORS (SEE OPERATING INSTRUCTIONS) SHALL BE TURNED OFF BEFORE REFUELING OF FUEL TANKS AND/OR PROPANE CONTAINERS. FAILURE TO COMPLY COULD RESULT IN DEATH OR SERIOUS INJURY.**

**MOST PROPANE GAS APPLIANCES ARE VENTED TO THE OUTSIDE. GASOLINE FUMES COULD ENTER THE APPLIANCE AND IGNITE FROM THE BURNER FLAME, CAUSING AN EXPLOSION OR FIRE.**



**! DANGER**

A GENERATOR PRODUCES CARBON MONOXIDE FROM EXHAUST FUMES FROM ITS ENGINE DURING OPERATION. CARBON MONOXIDE CAN BE FATAL! FOR YOUR SAFETY YOUR RECREATIONAL VEHICLE IS EQUIPPED WITH A CARBON MONOXIDE DETECTOR. WHEN THE DEVICE DETECTS CARBON MONOXIDE IN THE AIR IT WILL SOUND. CONSULT THE INDIVIDUAL DETECTOR'S USER MANUAL FOR SPECIFIC INSTRUCTIONS AND/OR AUDIBLE WARNING MEANINGS.

**! DANGER**

BE EXTREMELY CAREFUL WHEN FUELING A TANK. DO NOT SMOKE OR ALLOW OTHERS TO SMOKE WITHIN 20 FEET OF THE FUELING SYSTEM OR THE FUEL FILLER SPOUT OF THE VEHICLE TANK BEING FUELED. ALWAYS SHUT OFF ALL ENGINES, INCLUDING BUT NOT LIMITED TO, THE VEHICLE BEING FUELED, THE GENERATOR, AND THE TOW VEHICLE, ALL FUEL BURNING APPLIANCES AND THEIR PILOT LIGHTS. ALSO MAKE CERTAIN ALL AUTO-IGNITION APPLIANCES SUCH AS REFRIGERATOR, FURNACE, WATER HEATER, AND SO FORTH ARE IN THE OFF POSITION BEFORE FUELING. DO NOT DISPENSE FUEL WITHIN 20 FEET OF ANY IGNITION SOURCE. FUEL SPILLS REPRESENT A SERIOUS HAZARD, AND SHOULD BE CLEANED UP IMMEDIATELY. NEVER RESTART ANY ENGINE OR FUEL BURNING APPLIANCES. RELIGHT ANY PILOT LIGHTS, OR TURN AUTO IGNITION APPLIANCES BACK TO THE ON POSITION WHILE RAW FUEL IS PRESENT. FAILURE TO COMPLY COULD RESULT IN FIRE, SERIOUS INJURY OR DEATH.

ALSO REMEMBER WHEN OPERATING THE GENERATOR THAT EXHAUST GAS IS DEADLY! IT CONTAINS CARBON MONOXIDE, A POISONOUS GAS THAT CAN CAUSE UNCONSCIOUSNESS OR EVEN DEATH. IT IS AN ODORLESS, TASTELESS GAS FORMED DURING THE COMBUSTION OF FUEL IN THE GENERATOR ENGINE. NEVER RUN THE ENGINE UNLESS YOU ARE SURE THE EXHAUST GASES WILL BE SAFELY DISPERSED INTO THE ATMOSPHERE. ALWAYS BE SURE THE TAIL PIPE REMAINS UNBLOCKED, EXTENDS BEYOND THE SIDE OF THE UNIT AND WINDOWS NEAR THE EXHAUST ARE CLOSED. NEVER SITUATE YOUR VEHICLE IN A POSITION WHERE EXHAUST GASES HAVE ANY POSSIBILITY OF ACCUMULATING OUTSIDE, UNDERNEATH, OR INSIDE YOUR VEHICLE OR ANY VEHICLES NEAR YOU. OUTSIDE AIR MOVEMENTS CAN EVEN CARRY EXHAUST GASES INSIDE THE VEHICLE THROUGH WINDOWS OR OTHER OPENINGS THAT ARE REMOTE FROM THE EXHAUST OUTLET. OPERATE THE ENGINE ONLY WHEN SAFE DISPERSION OF EXHAUST GASES CAN BE ASSURED. DO NOT ALTER OR MODIFY ANY COMPONENT OF THE EXHAUST SYSTEM AT ANY TIME. IF YOU LOCATE OR SUSPECT DAMAGE TO THE SYSTEM, HAVE IT REPAIRED IMMEDIATELY OR DISCONTINUE USE OF THE GENERATOR UNTIL IT CAN BE REPAIRED.

BE AWARE OF CARBON MONOXIDE POISONING AND ITS SYMPTOMS WHICH INCLUDE DIZZINESS, INTENSE HEADACHE, VOMITING, NAUSEA, WEAKNESS, SLEEPINESS, INCOHERENCE, MUSCULAR TWITCHING OR THROBING IN THE TEMPLES. IF ANYONE IN THE RECREATIONAL VEHICLE EXPERIENCES ANY OF THESE SYMPTOMS, SHUT OFF THE GENERATOR AND IMMEDIATELY GO OUTSIDE INTO FRESH AIR. GET MEDICAL ATTENTION AS SOON AS POSSIBLE.

NEVER SLEEP WHILE THE ENGINE IS RUNNING. IT IS IMPOSSIBLE TO KNOW IF YOU ARE BEING AFFECTED BY CARBON MONOXIDE GAS WHILE ASLEEP.

### Operating Instructions:

1. Turn the switch labeled "Fuel Pump" located inside the recreational vehicle to the "ON" position.
2. Remove free end of ground wire from fueling compartment and attach to chassis ground of vehicle being fueled.
3. Set switch near the fueling station to the "ON" position.
4. Insert the nozzle into the tank and actuate the nozzle to dispense fuel.
5. Immediately turn the pump power off by resetting switch to the "OFF" position.
6. Turn the switch labeled "Fuel Pump" located inside the recreational vehicle to the "OFF" position.

### Maintenance:

The inlet strainer in the pump housing must be cleaned after every 50 hours of use. Refer to the maintenance section in the fuel transfer pump owner's manual for the inlet strainer removal and cleaning procedure.

### Generator

**Generator Option** — Some Skyline models have a generator option. If a generator is installed at a later date, the storage pan in the generator compartment must be removed before installing the generator. When installing the generator be sure to follow the generator installation instructions and all applicable codes and standards for a safe, trouble-free installation.

**Propane** — If your unit is factory equipped with this type of generator, one of the propane tanks will supply the generator and the second propane tank will supply the rest of the vehicle.

**Gasoline Generator** — If your unit is factory equipped with this type of generator, your unit will be equipped with a chassis mounted fuel tank with an automotive type fuel fill in the sidewall of the unit. This tank may be filled at a filling station using the same precautions recommended for fueling your tow vehicle. Always remove the fuel cap slowly, allowing pressure built up in the tank to escape gradually before completely removing cap. If you spill fuel on the side of your vehicle, clean it up immediately since fuel can dull or soften paint and damage other surfaces. Never overfill your tank, fuel will expand as temperatures increase. Stop filling when the automatic pump shuts off. Should you lose your fuel cap it must be replaced as soon as possible, with a cap of the same type. Consult the generator owner's manual for the proper type and octane of fuel for your generator and use only what is specified.

For either generator please follow the instructions in the owner manual for the generator in your owner package.

For your safety a carbon monoxide detector is installed in your recreational vehicle. Please see the section in this manual that describes the operation and care of the detector.

### Microwave Oven (Optional)

Installed microwaves operate on 120V AC power only and are popular for quick and convenient heating and cooking. Due to differing models used it is recommended that the Owner's Guide in the Unit Packet be read to for use on special features and operations.

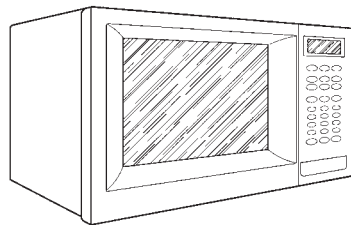

### Care and Maintenance

To clean exterior surface and the oven interior, use only mild nonabrasive soaps or detergents applied with a soft sponge or cloth. Never operate the microwave when oven is empty.

**Monitor Panel: See Plumbing Section**



## Range Hood

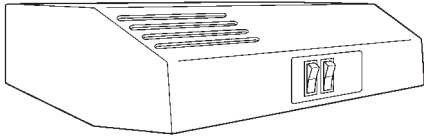

The range hood operates on 12V power and should be used as a ventilating system when cooking. Operational switches for the fan and/or light are on the front panel or top of the range hood.

### Care and Maintenance

Care of the range hood is similar to the range. Use warm soapy water and wipe off any grease before staining can occur. Do not use harsh chemical cleaners or abrasives. Clean the plastic light lens and filter by removing and washing in hot soapy water. Frequency of cleaning is dependent upon range usage.

### Range/Cook-Top

The gas oven and burners are operated with propane. The basic operation is similar to the range in your home. For additional information refer to the operating manual in your Owner's Information Kit.

A warning label has been placed in the cooking area to remind you to provide an adequate supply of fresh air for combustion. Unlike homes, the amount of oxygen supply is limited due to the size of the recreational vehicle, and proper ventilation when using the cooking appliance(s) avoids dangers of asphyxiation. It is especially important that cooking appliances not be used for comfort heating. As the danger of asphyxiation is greater when the appliance is used for long periods of time.

### Operation-Top Burners (Range or Cook-Top)

#### Prior to Lighting



Assure the gas supply to the trailer is turned "ON".

Open a window and/or vent for ventilation purposes.





Check for any hazards (flammable liquids, fabrics, objects near burners).

If gas smell is present, Do Not Light. See "What to do if you smell gas" at the beginning of this chapter.

Match-Light Models:

- All burner controls operate counter-clockwise  and must be pressed inward (toward the cooktop) to turn ON or LITE. Do not attempt to light more than one burner at a time.
- IMMEDIATELY light the burner by holding a long lit match or a handheld spark igniter designed for this purpose near the burner ports.
- To extinguish the top burner flame, turn the appropriate burner knob clockwise  to OFF.

Lighting Top Burners with Spark Ignition:

- Turn the appropriate burner knob counter-clockwise  to "ON" or "LITE". Do not attempt to light more than one burner at a time.
- Turn the "SPARK" knob clockwise , one "click", if the burner fails to light, continue turning the "SPARK" knob clockwise  until the burner lights.
- To extinguish the top burner flame, turn the appropriate burner knob clockwise  to "OFF".

The range or cook top installed is a propane gas appliance. Carefully read the manufacturer's manual for complete operational and safety instructions, provided in the unit packet, prior to using the appliance.

### Operation - Oven (if equipped)

Oven pilot must be lit prior to operating.

#### Lighting Oven Pilot

Be sure all valves and oven control knob are in the "OFF" position.

Assure the main gas supply is on.

Open oven door and smell for gas. If odor present — Stop! Read "What to do if you smell gas"

If no gas smell present

Lighting The Oven Pilot:

- Push in oven control knob and rotate counter-clockwise to PILOT ON.

## WARNING

**DO NOT OPERATE RANGE BURNERS UNLESS NEARBY PRIVACY DRAPE OR OTHER COMBUSTIBLES ARE SECURED. FAILURE TO COMPLY COULD RESULT IN A FIRE OR SERIOUS INJURY.**

## WARNING

**IT IS NOT SAFE TO USE COOKING APPLIANCES FOR COMFORT HEATING. COOKING APPLIANCES NEED FRESH AIR FOR SAFE OPERATION. BEFORE OPERATION:**

- OPEN OVERHEAD VENT OR TURN ON EXHAUST FAN
- OPEN WINDOW

**FAILURE TO COMPLY COULD RESULT IN DEATH OR SERIOUS INJURY. UNLIKE HOMES, THE AMOUNT OF OXYGEN SUPPLY IS LIMITED DUE TO THE SIZE OF THE RECREATIONAL VEHICLE, AND PROPER VENTILATION WHEN USING THE COOKING APPLIANCE(S) AVOIDS DANGERS OF ASPHYXIATION. IT IS ESPECIALLY IMPORTANT THAT COOKING APPLIANCES NOT BE USED FOR COMFORT HEATING, AS THE DANGER OF ASPHYXIATION IS GREATER WHEN THE APPLIANCE IS USED FOR LONG PERIODS OF TIME. FAILURE TO COMPLY COULD RESULT IN DEATH OR SERIOUS INJURY.**

## DANGER

**IF YOU SMELL PROPANE**

- EXTINGUISH ANY OPEN FLAMES, PILOT LIGHTS, AND ALL SMOKING MATERIALS
- DO NOT TOUCH ELECTRICAL SWITCHES
- SHUT OFF THE PROPANE SUPPLY CONTAINER VALVE(S) OR PROPANE SUPPLY CONNECTION
- OPEN DOORS AND OTHER VENTILATING OPENINGS
- LEAVE THE AREA UNTIL ODOR CLEARS
- HAVE THE PROPANE SYSTEM CHECKED AND LEAKAGE SOURCE CORRECTED BEFORE USING AGAIN

**FAILURE TO COMPLY COULD RESULT IN EXPLOSION RESULTING IN DEATH OR SERIOUS INJURY.**

## WARNING

**BURN INJURY, FIRE AND/OR EXPLOSION**

- USE RANGE OR COOKTOP ONLY FOR USE AS DESCRIBED IN THIS MANUAL.
- DO NOT LEAVE CHILDREN ALONE OR UNATTENDED IN AREA WHERE RANGE OR COOKTOP IS IN USE. NEVER ALLOW ANYONE TO SIT, STAND, OR CLIMB ON ANY PART OF THE RANGE COOKTOP. THEY COULD BE BURNED OR INJURED.
- DO NOT STORE THINGS CHILDREN MIGHT WANT ABOVE THE RANGE OR COOKTOP. CHILDREN COULD BE BURNED OR INJURED WHILE CLIMBING ON IT.
- DO NOT WEAR LOOSE OR HANGING GARMENTS WHEN USING THE RANGE OR COOKTOP. THEY COULD IGNITE IF THEY TOUCH AN OPEN FLAME AND YOU COULD BE BURNED.
- USE ONLY DRY POTHOLDERS. MOIST OR DAMP POTHOLDERS ON HOT SURFACES MAY RESULT IN BURNS FROM STEAM. DO NOT LET THE POTHOLDER TOUCH AN OPEN FLAME. DO NOT USE A TOWEL OR BULKY CLOTH FOR A POTHOLDER. IT COULD CATCH ON FIRE.
- DO NOT HEAT UNOPENED CONTAINERS. THEY COULD EXPLODE. THE HOT CONTENTS MAY CAUSE BURNS AND CONTAINER PARTICLES MAY CAUSE INJURY.
- DO NOT STORE FLAMMABLE MATERIALS ON, IN, OR NEAR THE RANGE OR COOKTOP. ANY FUMES CAN CREATE AN EXPLOSION AND/OR FIRE HAZARD.

**⚠ DANGER**

PROPANE POWERED APPLIANCES PRODUCE CARBON MONOXIDE. CARBON MONOXIDE CAN BE FATAL. FOR YOUR SAFETY, YOUR RECREATIONAL VEHICLE IS EQUIPPED WITH A CARBON MONOXIDE DETECTOR. WHEN THE DEVICE DETECTS CARBON MONOXIDE IN THE AIR IT WILL SOUND. CONSULT THE INDIVIDUAL DETECTOR'S USER MANUAL FOR SPECIFIC INSTRUCTIONS AND/OR AUDIBLE WARNING MEANINGS.

**⚠ WARNING**

NEVER USE WIRE BRUSHES OR ANY METALLIC ITEM FOR CLEANING RANGE PORTS OR ORIFICE. AS WIRE BRUSHES OR METALLIC ITEMS MAY SHED, LEADING TO A FIRE OR EXPLOSION.

**⚠ WARNING**

NEVER USE THE RANGE OR OVEN FOR EXTRA COMFORT HEATING. COOKING APPLIANCES ARE NOT DIRECTLY VENTED TO THE OUTSIDE AS ARE THE FURNACE/AIR CONDITIONING SYSTEMS.

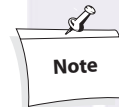

There may be specific locales or situations where laws prohibit the propane system from being operational. For example, it is usually illegal to operate the propane system when traveling through underground tunnels. Become familiar with these restrictions and make necessary adjustments to comply with these laws.

**⚠ WARNING**

BURN INJURY, FIRE AND/OR EXPLOSION

- DO NOT OPERATE RANGE OR COOKTOP IF IT IS DAMAGED OR NOT WORKING PROPERLY.
- KNOW WHERE YOUR VEHICLE'S MAIN PROPANE GAS SHUTOFF IS LOCATED.
- VERIFY SUFFICIENT GAS SUPPLY BEFORE ATTEMPTING TO LIGHT ANY TOP BURNER. AIR IN THE GAS SUPPLY LINE WILL SIGNIFICANTLY DELAY BURNER IGNITION, AND A BURNER MAY LIGHT UNEXPECTEDLY AS THE AIR IN THE LINE CLEARS OUT AND IS REPLACED BY PROPANE GAS; THIS UNEXPECTED IGNITION MAY BURN YOU. AIR MAY BE INTRODUCED INTO THE SUPPLY LINE WHEN THE VEHICLE GAS BOTTLE IS REPLACED, DURING SERVICING OF OTHER GAS APPLIANCES, ETC.
- IF ANY BURNER SHOULD EXTINGUISH (AFTER INITIALLY LIGHTING OR DUE TO ACCIDENTAL BLOW-OUT), TURN ALL BURNER KNOBS CLOCKWISE TO OFF AND WAIT FIVE (5) MINUTES BEFORE AGAIN ATTEMPTING TO LIGHT THE BURNER.
- DO NOT TOUCH TOP BURNERS, BURNER GRATES, OR OTHER AREAS NEAR TOP BURNERS DURING AND AFTER USE. DO NOT LET CLOTHING OR OTHER FLAMMABLE MATERIALS TO CONTACT TOP BURNERS OR AREAS NEAR TOP BURNERS UNTIL THEY HAVE HAD SUFFICIENT TIME TO COOL.

(WARNING Continued on Page 31)

- b. Light oven pilot located near the back of the oven, under the broiler shelf and to the left of the oven burner.
- c. Set the oven control knob to PILOT ON to maintain pilot flame. The oven and broiler are now ready for operation. The oven pilot has been factory set and requires no further adjustment.
- d. To extinguish the oven pilot, push in the oven control knob and rotate clockwise to OFF. Extinguish all pilots when refueling or traveling.

Lighting The Oven Burner:

- a. Light the oven pilot as described above.
- b. With the oven control knob set to PILOT ON, push in and rotate the knob counter-clockwise to the desired temperature setting or to BROIL. The oven will pre-heat in approximately 10 minutes. For best results, always pre-heat the oven before use.
- c. The oven is equipped with a safety ignition system that requires a minimum of 30 seconds to operate after turning the oven control ON. This delay is normal.
- d. To extinguish the oven burner, rotate the knob clockwise to PILOT ON. The oven pilot will remain lit.
- e. For complete shutdown, push in and rotate the knob clockwise to OFF.

Using The Broiler:

- a. Light the oven pilot as described in #2 (above).
- b. Push in and rotate the oven control knob counter-clockwise to BROIL.
- c. Center a broiler pan under the broiler flame.
- d. Move and turn the food over frequently to ensure even browning and cooking.

**Care and Maintenance**

Before cleaning make sure all knobs are in the "OFF" position and wait until all surfaces, including burners, are cool. Use warm soapy water only. Do not use oven cleaners, bleach or rust removers on the range/cook top surface. Wipe up any spills as soon as possible to avoid possible discoloration or pitting on the surface. Check burner ports when cleaning. If the ports or the orifice are clogged, carefully clean with a toothpick.

**RV Refrigerator**

The refrigerator installed is a propane gas appliance. Carefully read the manufacturer's manual for complete operational and safety instructions, provided in the unit packet, prior to using the appliance.

**Operation**

The refrigerator operates on either 120V AC or propane gas and has a gravity-based cooling system. This system requires that the recreational vehicle be level for efficient operation. The cooling coils are sloped to allow continuous movement of the liquid chemicals. If the unit is not level for extended periods, the flow of these chemicals will slow and pool inside the tubing, resulting in a loss of cooling.

During towing, the leveling is not as crucial as the movement of the trailer will prevent the liquid inside the tubing from pooling. If needing to park for several hours, the trailer should be leveled if operating the refrigerator, or the refrigerator needs to be turned off.

Placing a small bubble level inside of refrigerator will assist in determining if level for operational efficiency.

When starting the refrigerator for the first time or after extended storage, allow up to four hours for the cooling cycle to become fully operational.

**Operational Controls**

**Auto Mode:** The control system on the refrigerator will automatically select between gas and AC electric operation. AC will always be selected if available. If AC becomes unavailable, the refrigerator will switch to gas mode operation. When in auto mode the indicator lamp on the control panel will be lit.

**Gas Mode:** This mode when selected provides gas operation only. The indicator lamp for auto mode will not be lit.

## Care and Maintenance

**Exterior:** Ventilation of the refrigerator is essential. Make sure the vents are clear of any obstructions such as bird/insect nests, spider webs, or any other debris. Periodically clean the coils on the back of the refrigerator with a soft bristled brush. At no time should any combustible materials, such as gasoline, flammable liquids or vapors be stored near the refrigerator.

**Interior:** When cleaning the interior lining of the refrigerator, use a weak solution of baking soda and warm water. Use only warm water, however, when cleaning the finned evaporator, ice trays and shelves. Never use harsh chemicals or abrasive cleaners to clean these parts or their protective coatings will be damaged.

**Defrosting:** When defrosting the refrigerator, shut off the power by turning the main power button to the off position. Remove any food and leave the drip tray under the finned evaporator. Remove light bulb or cover the switch with a piece of tape. Leave the door(s) open and empty drip pan when necessary. Dry with a soft cloth when done.

**ANY SERVICE TO THE REFRIGERATOR MUST BE PERFORMED BY A QUALIFIED REPAIR TECHNICIAN.**

### Roof Vents

Manual and/or power roof vents are installed on Skyline recreational vehicles. (For Fan-Tastic Vent, see the information on this specific product in this section.) Operate the roof vents when showering, bathing, washing dishes, or anytime hot water is used, as it allows moisture to escape. Ventilation is extremely important in reducing condensation formation.

### Safety

Fire safety is important whether at home or in a recreational vehicle. The best way to limit fire risk is by prevention. Follow the manufacturers' instructions on the use of all appliances and observe all safety warnings and instructions included.

Before camping, make certain you are familiar with the locations of all safety equipment inside the coach and all emergency exit windows as well as doors. An escape plan for emergencies whether at home or camping is always a good idea.

### Before a Fire Starts

- Remove trash and stored items of outlived usefulness, particularly from the vicinity of furnaces and heaters and from hallways and exit areas.
- Exercise care in the use of electricity. Do not overload electrical outlets with many appliances, use only appropriate fuses, and do not hang electrical cords over nails or run under carpets. Have cords replaced when they begin to fray or crack and have electrical work done by competent electricians.
- Do not store gasoline or flammable cleaners inside the trailer. Most cleaning jobs can be done with readily available non-flammable cleaners that are safer to use and store. Also any type of gasoline powered equipment must not be stored inside your travel trailer unless the fuel tank and carburetor have both been completely drained.
- To avoid the danger of spontaneous ignition, dispose of rags wet with oil, polishes, or other flammable liquids in outdoor garbage cans.
- Inspect your trailer often for these and other hazards.
- Plan for escape from every area of the trailer; discuss escape routes with your family, and actually rehearse escape. You might have to find your way out in thick smoke or darkness.
- Learn how to extinguish common fires in early stages. Your unit is equipped with a fire extinguisher. Everyone should know how to operate it. The gauge on the extinguisher shows whether it needs to be replaced. It should be checked regularly. A minor (kitchen) flare-up may be extinguished with ordinary baking soda. It's inexpensive, easy to clean up, and has lots of other uses. **NEVER** use water.
- Clothing afire is a prelude to tragedy. Do not wear (or permit children to wear) loose, frilly garments if there is any chance at all of accidental contact with a stove burner or other source of fire.
- Exercise extreme care with smoking materials and matches, major causes of destructive fire. Do not leave these where children can reach them.

(WARNING Continued from  
page 30)

- **MAKE SURE THE UTENSILS YOU USE ARE LARGE ENOUGH TO CONTAIN FOOD AND AVOID BOIL OVERS AND SPILLOVERS. HEAVY SPLATTERING OR SPILLOVERS LEFT ON THE COOKTOP CAN IGNITE AND BURN YOU.**
- **DO NOT DROP PANS ON THE PORCELAIN SURFACE. CRACKS OR CHIPS IN THE PORCELAIN SURFACE MAY RESULT.**
- **BE SURE THAT GLASS COOKING UTENSILS ARE SAFE FOR USE ON THE COOKTOP. ONLY CERTAIN KINDS OF GLASS UTENSILS ARE SUITABLE FOR SURFACE OR TOP BURNER USE WITHOUT BREAKING DUE TO THE SUDDEN CHANGES IN TEMPERATURE.**
- **NEVER LEAVE TOP BURNERS UNATTENDED. A BOIL OVER COULD RESULT AND CAUSE SMOKING AND GREASY SPILLOVERS THAT MAY IGNITE.**
- **TURN PAN HANDLES INWARD, BUT NOT OVER OTHER TOP BURNERS. THIS REDUCES THE CHANCE OF BURNS DUE TO BUMPING PAN.**
- **GREASE IS FLAMMABLE. NEVER ALLOW GREASE TO COLLECT AROUND TOP BURNERS OR ON COOKTOP SURFACE. WIPE SPILLOVERS IMMEDIATELY.**
- **DO NOT USE WATER ON GREASE FIRES. NEVER PICK UP A FLAMING PAN. SMOOTHER A FLAMING PAN WITH A TIGHT-FITTING LID OR COOKIE SHEET. FLAMING GREASE OUTSIDE OF THE PAN CAN BE EXTINGUISHED WITH BAKING SODA OR A MULTIPURPOSE DRY CHEMICAL OR FOAM-TYPE FIRE EXTINGUISHER.**
- **USE CARE WHEN LIGHTING A TOP BURNER BY HAND. IF THE BURNER LIGHTS UNEXPECTEDLY, OR YOUR HAND IS CLOSE TO THE BURNER, YOU MAY BE BURNED.**
- **BURNER FLAME SHOULD NOT EXTEND BEYOND THE EDGE OF THE COOKING UTENSIL. THE FLAME COULD BURN YOU AND CAUSE POOR COOKING RESULTS.**
- **BE SURE ALL CONTROL KNOBS ARE TURNED TO OFF WHEN YOU ARE NOT COOKING. SOMEONE COULD BE BURNED OR A FIRE COULD START IF A BURNER IS ACCIDENTALLY LEFT ON.**

**DANGER**

**ALL PILOT LIGHTS, APPLIANCES, AND THEIR IGNITORS (SEE OPERATING INSTRUCTIONS) SHALL BE TURNED OFF BEFORE REFUELING OF MOTOR FUEL TANKS AND/OR PROPANE CONTAINERS. FAILURE TO COMPLY COULD RESULT IN DEATH OR SERIOUS INJURY.**

**MOST PROPANE GAS APPLIANCES ARE VENTED TO THE OUTSIDE. GASOLINE FUMES COULD ENTER THE APPLIANCE AND IGNITE FROM THE BURNER FLAME, CAUSING AN EXPLOSION OR FIRE.**



IF A FIRE STARTS AND YOU HAVE ANY DOUBT ABOUT WHETHER YOU CAN EXTINGUISH IT, **IMMEDIATELY** GET EVERYONE OUT OF THE TRAILER AND A SAFE DISTANCE AWAY TO REDUCE THE RISK OF SERIOUS INJURY OR DEATH. **NEVER** REENTER A BURNING TRAILER.

- If you see, smell, or hear any hint of fire, evacuate everyone immediately, but don't compound tragedy by attempting a rescue through a gauntlet of flames or thick smoke. Call the fire department as soon as possible. Don't attempt to extinguish a fire unless it is confined to a small area and your extinguishing equipment is equal to the task.
- If your clothing ignites, roll over and over on the ground or the floor. Running will just fan the flames. Teach the proper procedure to your children.
- Before opening a door if you suspect fire in another part of the trailer, feel the inside of the door with the palm of your hand. If it's hot, don't open it. If smoke is pouring into the room under the door, stuff bedding or clothing into the crack; and get out of the trailer quickly. Identify egress windows and familiarize yourself with how to open all windows in your trailer. You may need to exit from a window if a fire or other emergency occurs.
- In smoke, keep low. Gases, smoke, and air heated by fire rise, and the safest area is at the floor. Cover mouth and nose with a damp cloth, if possible. Don't assume that clean air in a fire situation is safe. It could contain carbon monoxide, which, before it kills you, affects judgment, hampering escape.

### Fire Safety Reminders

Fire is an unexpected event even with the best of housekeeping, safety features, and fire prevention procedures. Remember these helpful hints when faced with a fire:

- When reporting a fire, speak calmly, don't panic, and give all the needed information.
- Remember to feel the door before you exit. If it is hot, don't open it. The smoke and heat may knock you out. Look for another route of escape.
- If the door seems to be cool enough, open the door cautiously, ready to slam it shut if flames should burst in. If the path is clear, then escape.
- Remember to close the door after you — this will slow down the spread of the fire.
- Never reenter a burning trailer.
- Above all, don't panic.

### If you have small children, you should also consider the following:

- Make sure children are never left unattended.
- Teach your children how to dial the emergency number "911" and ask for assistance.
- Instruct the baby-sitter to follow the evacuation plan and rendezvous point which you have established for your family if a fire should occur.

### In general, plan ahead for safer living

- Know your new trailer.
- Learn the "do's" and "don'ts" of safer living as outlined in this manual.
- Follow the instructions provided with your trailer and the equipment in it.
- Be sure that all members of your family are safety conscious.
- Finally, take a few minutes with your family to read and understand the safety tips we have given you.

### Emergency Exits

Every trailer is designed to the Standard for Recreational Vehicles —NFPA 1192, with a minimum of two exits which are remote from one another. They are either two doors or a door and a window, which is marked as an exit. Be sure that these exits are accessible and left free for exit. Be certain that you and your family know the location of the "egress" window and understand its operation as described on the window label. "Egress" windows are specially designed to make escape faster and easier in an emergency. Do not place furniture in front of this window so that it might become blocked.

### Egress Windows

Egress or "Emergency Exit" Windows are labeled from the factory with the word EXIT. All Egress windows can be distinguished by red operational handles or levers. Dependent upon the window type, an egress window may be a large section or an entire window. Review the locations and operational instructions posted upon the window with all occupants.



### WARNING

ACTUATION OF YOUR CO ALARM INDICATES THE PRESENCE OF CARBON MONOXIDE (CO) WHICH CAN KILL YOU. IF THE ALARM SOUNDS; 1) OPERATE THE RESET/SILENCE BUTTON; 2) CALL YOUR EMERGENCY SERVICES (PHONE NUMBER \_\_\_\_\_) (FIRE DEPARTMENT OR 911); 3) IMMEDIATELY MOVE TO FRESH AIR - OUTDOORS OR BY AN OPEN DOOR/WINDOW. DO A HEAD COUNT TO CHECK THAT ALL PERSONS ARE ACCOUNTED FOR. DO NOT REENTER THE PREMISES NOR MOVE AWAY FROM THE OPEN DOOR/WINDOW UNTIL THE EMERGENCY RESPONDERS HAVE ARRIVED, THE PREMISES HAVE BEEN AIRED OUT, AND YOUR ALARM REMAINS IN ITS NORMAL OPERATION. 4) AFTER FOLLOWING STEPS 1-3, IF YOUR ALARM REACTIVATES WITHIN A 24 HOUR PERIOD, REPEAT STEPS 1-3 AND CALL A QUALIFIED APPLIANCE TECHNICIAN. (PHONE NUMBER \_\_\_\_\_) TO INVESTIGATE FOR SOURCES OF CO FROM FUEL BURNING EQUIPMENT AND APPLIANCES. AND INSPECT FOR PROPER OPERATION OF THIS EQUIPMENT. IF PROBLEMS ARE IDENTIFIED DURING THIS INSPECTION HAVE THE EQUIPMENT SERVICED IMMEDIATELY. NOTE ANY COMBUSTION EQUIPMENT NOT INSPECTED BY THE TECHNICIAN AND CONSULT THE MANUFACTURERS' INSTRUCTIONS, OR CONTACT THE MANUFACTURER DIRECTLY. FOR MORE INFORMATION ABOUT CO SAFETY AND THIS EQUIPMENT.

## Fire Extinguisher

Each recreational vehicle includes a fire extinguisher, which is located near the main entry door. The fire extinguishers are rated for Class B (gasoline, grease, and flammable liquids) and Class C (electrical) fires. Test and operate according to manufacturer instructions.

## Flashlight

For your convenience and security, a cordless rechargeable flashlight is available in some models. Located near the main entrance door, simply remove the flashlight from its charging case and turn on. After switching it off, replace the flashlight in its self-charging case for recharging as power is available.

## Propane, Carbon Monoxide Detectors, and Smoke Alarms

Your travel trailer was designed and built to meet all applicable standards in effect on the date of manufacture for normal recreational use. For your safety a propane detector, carbon monoxide detector and a smoke detector have been installed in the kitchen/hall/living area.

Since propane is heavier than air, the propane detector has been mounted near the floor. Test the detector after the trailer has been in storage, before each trip, and once a week during use. Follow the test procedure recommended in the manufacturer's operating instructions.

The carbon monoxide detector warns of excessive levels of carbon monoxide given off by internal combustion engines and some other fossil fuel burning appliances. Test the carbon monoxide detector after the trailer has been in storage, before each trip, and once a week during use. Note, the carbon monoxide detector requires a ten (10) minute warm up period once it is energized. See the manufacturer's operation instructions for operation and testing procedures. If the detector does not operate properly, have the detector repaired or replaced. The carbon monoxide detector and propane leak detector are often built into a single unit.

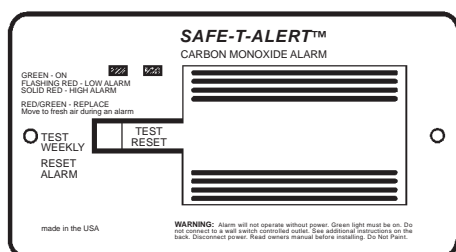

Carbon Monoxide Detector

Both the Propane detector and the CO detector are wired to the 12 volt system of your trailer. They will function properly whenever 12 volt power is available from the tow vehicle through the 7-way power cord, the RV battery, or when the converter is energized through the 120 volt shoreline. **For protection in all circumstances (i.e. dry camping) a fully charged RV battery must be properly installed.**

Indications of CO poisoning are (but not limited to):

### Mild Exposure

- Symptoms of the flu (minus a fever)
- Slight Headache
- Dizziness
- Fatigue

### Medium Exposure

- Sever Throbbing Headache
- Drowsiness
- Confusion
- Fast Heart Rate

### Extreme Exposure

- Unconsciousness
- Convulsions
- Cardiorespiratory Failure
- Death



**IF THE ALARM SOUNDS, PROVIDE VENTILATION BY OPENING WINDOWS AND DOORS. THE CO BUILD-UP MAY DISSIPATE BEFORE HELP ARRIVES, BUT MAY BE ONLY TEMPORARILY SOLVED. IT IS CRUCIAL THAT THE SOURCE OF THE CO IS DETERMINED AND REPAIRED.**



**THE CO ALARM CAN ONLY WARN YOU IN THE PRESENCE OF CO. IT DOES NOT PREVENT CO FROM OCCURRING NOR CAN IT SOLVE AN EXISTING CO PROBLEM.**



**CARBON MONOXIDE CAN BE FATAL! WHEN THE DEVICE DETECTS CARBON MONOXIDE IN THE AIR IT WILL SOUND. CONSULT THE INDIVIDUAL DETECTOR'S USER MANUAL FOR SPECIFIC INSTRUCTIONS AND/OR AUDIBLE WARNING MEANINGS.**



**WARNING**

TEST SMOKE ALARM OPERATION AFTER VEHICLE HAS BEEN IN STORAGE, BEFORE EACH TRIP, AND AT LEAST ONCE PER WEEK DURING USE. FAILURE TO COMPLY MAY RESULT IN SERIOUS INJURY.

For your safety and to keep your carbon monoxide alarm in good working order, follow the steps below.

- Verify the unit alarm, lights and battery operation by pushing the “Test” button weekly.
- Vacuum the CO alarm cover with a soft brush attachment once a month to remove accumulated dust.
- Instruct children never to play with the CO alarm. Warn children of the dangers of carbon monoxide poisoning.
- Never use detergents or solvents to clean the carbon monoxide alarm.
- Avoid spraying paint, hair spray, air fresheners or other aerosols near the CO detector.
- Do Not paint the CO detector. Paint will seal the vents and interfere with the sensor ability to detect CO.
- Do Not place a diaper pail near the CO detector.
- Test the alarm operation after your trailer has been in storage, before each trip and at least once a week during the camping season.

A battery-powered smoke alarm complying with NFPA 1192 is mounted on the wall in the living / cooking area of your trailer. Please read the smoke alarm's Owner's Manual for details on testing and caring for this important safety device. Test the smoke alarm after the trailer has been in storage, before each trip, and once a week during use. Depress and hold the test button on the cover for up to 20 seconds. The horn should sound a loud alarm. If the horn does not sound, check that the battery is inserted properly and is fresh. If the battery is dead, replace it promptly and retest the alarm. If the alarm still does not sound, have it replaced.

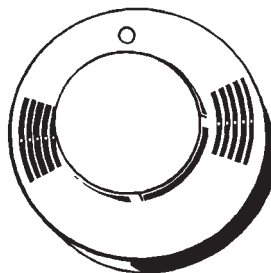

Smoke Alarm

**AM/FM Radio, CD Player**

Refer to your radio and CD/tape player manufacturer's instruction manual for specific operating and cleaning instructions.

---

## Chapter 5: Electrical System

The electrical system in recreational vehicles is a combination 12 Volt DC (Direct Current) and 120 Volt AC (Alternating Current) system. Every facet of the electrical system is carefully engineered and installed to comply with the National Fire Protection Association Standard 1192 and the “National Electric Code.” To understand this system, simply put, the 12 Volt system is what an automobile uses and the 120 Volt system is what most households use.

### 12 Volt System - DC

The 12 Volt system can be powered in three different ways: a separate RV battery, the converter changing 120V AC to 12V DC or by the tow vehicle's 12 Volt system. The water pump, most lights, power vents, and other appliances are powered by the 12 Volt system.

The heart of the 12 Volt system is the battery (not supplied by Skyline). Batteries are essentially storage devices for electrical energy. Most batteries used in RVs are RV/Marine Deep Cycle, Lead-Acid types. These batteries contain lead plates and liquid sulfuric acid electrolytes in sections called cells.

**WARNING**

FAILURE TO CORRECT AN ELECTRICAL MALFUNCTION COULD RESULT IN SERIOUS INJURY OR EVEN DEATH.

Electrolytes are lost whenever a battery discharges energy or is recharged. The level of the electrolyte must stay above the plate in each cell. Many premature battery failures occur because the electrolyte level was not maintained. For maintenance and storage information see the Care and Maintenance Section.

### 120 Volt A/C System

The 120 Volt system is supplied by plugging the power cord (shore cord) into an outside source. It furnishes current to the 120 Volt appliances and fixtures like the roof air conditioners, the refrigerator, some lighting and all 120 V receptacles. It also supplies power for the 12 Volt trailer system through the converter. The 120 Volt electrical system is protected by circuit breakers located in the 120 Volt/12 Volt load center located inside your travel trailer. If you own a travel trailer equipped with the optional 240 Volt electrical service, there is a main electrical box with breakers in addition to the 120 Volt/12 Volt load center. The most common cause of a circuit breaker to open is an overloaded circuit. An example of an overloaded circuit is when a space heater is plugged into the same outlet as the toaster. If this happens, reduce the load on the circuit and reset the breaker. If the breaker trips again, have a qualified person locate the trouble and correct it before restoring the circuit breaker to its normal position.

### Power Cord/Shore Cord

The power cord, often referred to as shore cord or shoreline, is a heavy-duty cable with a 3 or 4 prong grounding plug on one end and connects directly to the power converter inside the unit on the other end. This cord is used to plug into an external 120V source. Most cords are typically 30 Amp plugs (3 prong), although certain components or ordered options on some units will require a 50 Amp (4 prong plug). This cord is designed to ground the electrical system.

Do not plug in shore cord while under load. Make sure all appliances are turned off and the main breaker is off prior to connecting shore cord. After plugging in the shore line, restore the main breaker to the "ON" position, then turn on the desired appliances.

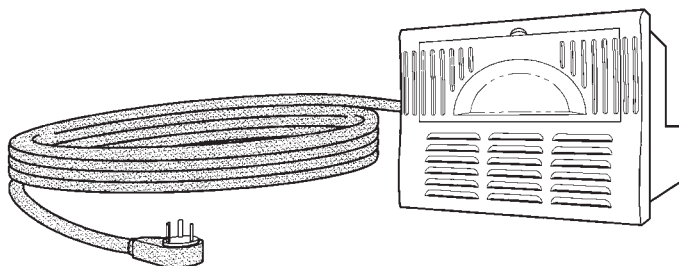

## 30 Amp, 50 Amp and Available Power

### 30 Amp Capability

30 Amp service is 120 Volt service limited to a total draw of 30 amps. The power cord from the RV is three pronged. 30 Amp service is the most common in the RV industry and used widely in campgrounds through the United States. With 30 Amp service any appliance in the RV can operate by itself. However, due to the 30 Amp limitations, you may not be able to run a certain group or all appliances at the same time. For instance, most air conditioners will draw up to 16 Amps on start up and about 12 Amps when running continuously. While running the microwave and pulling 15 Amps, you decide to turn on the air conditioner, the initial draw of up to 16 Amps may overload the circuit, causing a breaker to blow. Below is a reference chart to show typical amperage draw on common appliances and fixtures.

### 50 Amp Capability (Optional)

If the RV has 50 amp built-in, the power cord will have 4 prongs, unlike the 3 of 30 Amp service, capable of running up to 50 amps of draw. 50 Amp capability is also 120 volt service, however it retains unique properties. With the 30 amp plug, only one prong carries the 120V power. With the 50 Amp plug, two of the four prongs carry 120 Volt, allowing for 240 Volt power if needed for a special appliance and the ability to set up power needs according to appliance application. As such, a unit built with two air conditioners, can run both at the same time, while running other appliances commonly used within an RV.

#### Note

Before plugging in the RV shore cord, turn off all electrical appliances and set main breaker to off position so as not to start under a "load", which could cause a breaker to open. Reverse this process before unplugging.

#### Note

The power cord prongs should always be clean and solid. Clean with a contact cleaner, emery cloth and or a nail file. Electrical connections work better when clean.

#### WARNING

NEVER REPLACE CIRCUIT BREAKERS OR FUSES OF HIGHER CURRENT RATING THAN THOSE ORIGINALLY INSTALLED. THIS COULD OVERHEAT THE WIRING AND START A FIRE.

APPLIANCE	AMPERAGE CONSUMED
Roof Air conditioner (Continuous)	12
Roof Air Conditioner (Initial Start)	Up to 16
Electric Water Heater	12
Microwave	13
Converter	9-12
Space Heater	10-15
Toaster	10
Refrigerator	3.5
TV or VCR	1
Hair Dryer	Up to 14
110 Volt Light	1

**CAUTION**

Extreme care should be used if adapter plugs are added. Polarity must be checked before connecting the plug. NEVER use a "cheater" adapter unless an additional ground is provided, park management is consulted, and polarization is determined.

**Available Power**

Despite the power system built into a recreational vehicle, the power system is only as good as the power supply. What this means is that if a campground has only 30 Amp service available, a recreational unit with 50 Amp capability will only have 30 amp service. A special adapter is required to reduce the 50 amp plug to fit the 30 Amp campground receptacle. In other words, with only 30 amps available only one air conditioner at a time may be used. As well, there are some campgrounds that may only carry 15 or 20 Amp power. The best way to know what amperage is available is to call ahead and always carry adapters, available at most Skyline RV dealers and RV parts stores.

**About Campground Electrical Service**

Campground electrical service varies. Make no assumptions when hooking up to a site for electric. Check the polarity before plugging in. An inexpensive polarity checker is available from your dealer and can save a lot of headaches. Just because the RV has 30 or 50 Amp power cord, it does not mean 30 or 50 is available. Adapters from 50 to 30, and 30 to 15/20 are available. Ask your dealer or check any RV supply store.

Low voltage can damage RV electrical systems and/or components like air conditioners, televisions, microwaves, etc. Items such as voltage meters, surge and brownout protectors are available from electrical and RV accessories stores to help you monitor the electrical current entering the trailer.

**Converter**

Your travel trailer is equipped with a load center. The load center has a built-in converter that automatically converts 120-volt current to 12-volt current for use by those circuits which require it and also recharges your battery. Have your dealer go over your load center with you and instruct you concerning the battery charging features. No switching is necessary. If an exterior source of power is connected, the converter automatically switches to this source rather than the trailer battery. If the converter is not connected to a 120-volt power source your 12-volt system will draw power from the battery.

Whenever city power (120V) is available it should be used to avoid discharging the trailer battery. When the power cord between the travel trailer and the tow vehicle is connected, the trailer and tow vehicle electrical systems operate as one. The trailer battery is recharged by the tow vehicle's alternator and when parked, the tow vehicle battery can be discharged by prolonged power usage in the trailer. Consequently, when parked and operating from the trailer batteries, the cord between the tow vehicle and travel trailer should be disconnected to avoid running down your tow vehicle battery. The trailer battery can be recharged by starting the tow vehicle and reconnecting the power cord. When operating off batteries it is wise to use lights and power sparingly.

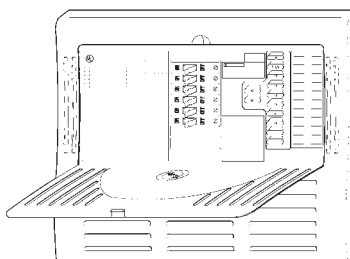

Electrical Panel/Converter

## GFCI — (Ground Fault Circuit Interrupter)

Protection against ground fault is provided on lavatory, kitchen, and outside receptacle circuits with a special GFCI receptacle, or by a GFI circuit breaker. These devices are designed to break the circuit when it detects an imbalance in the current flow. The imbalance can be due to an appliance failure which could result in serious injury or death to the user.

Familiarize yourself with the operation and testing of the GFCI. It is an important device which could save your life. If the GFCI breaks the circuit, be sure to have the appliance you were using serviced prior to using it again.

Even with the protection of a GFCI, electrical shock may be felt but will usually be of less than normally dangerous duration, except for persons with heart problems or other conditions that may make them particularly susceptible to serious injury or death from electrical shock. While the GFCI affords a degree of protection not previously available, there is no substitute for remembering that **ELECTRICITY CAN BE DANGEROUS WHEN HANDLED CARELESSLY OR MISUSED AND CAN CAUSE SERIOUS INJURY OR DEATH.**

### Testing

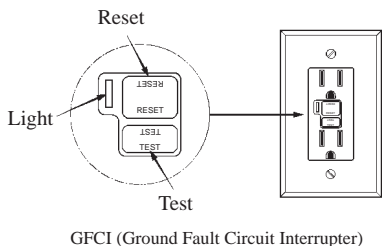

The GFCI receptacle should be tested at least once a month or prior to every trip. To test the GFCI, push the TEST button. The RESET button will pop out. Power is now off at all outlets protected by the GFCI receptacle. Push in the RESET button to restore power. The test is complete when the reset button remains pushed in. If the RESET button does not pop out when testing, the GFCI is malfunctioning and no outlets should be used on this circuit, as protection is lost. Call your dealer if the GFCI malfunctions.

### 7-Way Plug

The seven-pin connector on the trailer hitch transfers electrical power from the tow vehicle battery to the trailer brakes, exterior lighting system, and battery. Keep the plug clean, tight, and protected from the elements. Inspect it carefully every time you hitch up. Be certain that your dealer has run a “charge line” from the alternator on the tow vehicle to terminal number four on the trailer’s 12-volt connector. This wire should be a minimum 10-gauge stranded, insulated copper. A 30 amp circuit protector should be installed near the alternator connection. This charge line will keep the trailer battery charged as you travel.

Because the wiring systems of many tow vehicles use separate wires for turn signals and stop lights, you may need to purchase a taillight converter. This converter will combine these wires so that they can be connected to the trailer lighting system. Most factory-installed towing packages include a trailer wire harness that will perform this function if required. If you tow more than one type of trailer, you also may need to purchase an adapter to accommodate differences in the wiring systems.

### Care and Maintenance

No	Color	Item	Wire Gauge*
1	White	Common Ground	8
2	Blue	Electric Brake	12
3	Green	Tail Lights and License	14
4	Black	Battery Charge	8
5	Red	Left Stop and Turn	14
6	Brown	Right Stop and Turn	14
7	Yellow	Center Auxiliary	14

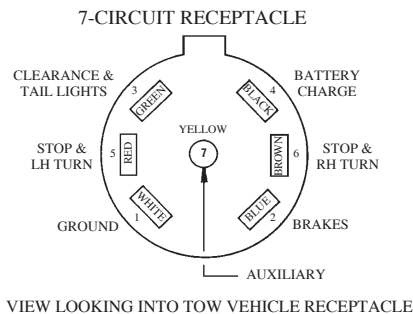

Maintaining the 7-Way Plug requires little effort. Store safely when not in use and clean the prongs as needed. Please see your dealer if repair work is necessary.

Typically, the wires within the 7-Way plug are color-coded as identified in the graphics above.

## CAUTION

There is no known device that offers complete protection against the hazard of electrical accidents under all conceivable conditions. For example, the GFCI does not protect a person who simultaneously contacts both “hot” wire and the neutral wire.

## WARNING

DO NOT INSTALL A FUSE IN THE CIRCUIT BETWEEN THE TOW VEHICLE BATTERY AND AN ELECTRIC OR ELECTRONIC BRAKE CONTROLLER. A BLOWN FUSE WOULD CAUSE THE CONTROLLER TO CEASE FUNCTIONING BOTH AUTOMATICALLY AND MANUALLY, CAUSING LOSS OF TRAILER BRAKING WITH NO ADVANCE WARNING. PROVIDE CIRCUIT PROTECTION PER INSTRUCTIONS PROVIDED BY THE MANUFACTURER OF THE BRAKE CONTROLLER.

**WARNING**

DISCONNECT THE 7-WAY CORD FROM TOW VEHICLE PRIOR TO TESTING BREAKAWAY SWITCH. FAILURE TO DO SO MAY CAUSE DAMAGE TO THE BRAKE CONTROLLER.

**WARNING**

THE BREAKAWAY SWITCH IS FOR EMERGENCY USE ONLY.

**WARNING**

DO NOT TOW A TRAILER WITH A MALFUNCTIONING BREAKAWAY SWITCH. DO NOT LEAVE THE PULL PIN OUT OF THE BREAKAWAY SWITCH FOR MORE THAN A FEW MINUTES, OR THE BATTERY WILL BE DRAINED. DO NOT USE THE BREAKAWAY SWITCH FOR A PARKING BRAKE.

## Brakes, Electric

Included in the unit packet is an extensive manual by the manufacturer of the brakes, axles, hubs and drums. Please refer to this manual for information on any of these systems.

### Breakaway Switch

The breakaway switch is located on the trailer tongue. It has a steel cable (lanyard) fastened to it which will reach to the frame of the tow vehicle. This device is one of the most vital components on your trailer's braking system. It automatically applies the trailer brakes if the tow vehicle and trailer become uncoupled while in motion. The breakaway switch operates when a pull pin linked by the cable to the tow vehicle is separated from the switch. When the switch closes, power for brake application is supplied by the on-board trailer battery. The steel lanyard must be anchored to the tow vehicle when the trailer is hitched up. Secure this cable loop to the permanent frame of the tow vehicle, or a part of the hitch that is non-removable. **DO NOT FASTEN THE BREAKAWAY SWITCH LANYARD TO THE HITCH BALL OR ANY OTHER REMOVABLE PART OF THE HITCH.**

Do not let the lanyard, which is connected to the pin, drag upon the ground. Inspect the condition of the lanyard prior to travel. Since the breakaway safety feature operates on the trailer battery, insure the battery is fully charged and the terminals are clean. Testing the switch prior to traveling is recommended (see below). If a problem is noted, or if the switch fails during testing, please call your dealer.

### How to Test the Breakaway Switch

Test breakaway switch operation before each trip, as follows:

- a. Hitch the trailer to the tow vehicle.
- b. Pull out the breaker switch actuating pin.
- c. Test the breaker by attempting to drive away. If the breakaway switch is functioning properly, the trailer brakes will be activated.
- d. If the brakes are not activated, check to make sure that the trailer battery is connected and fully charged, and the trailer brakes are properly adjusted.
- e. If the trailer brakes do not operate after making these checks, see your dealer for repair.
- f. Reinsert the breakaway switch actuating pin before towing the trailer.

### The Braking System

The electric brakes on your trailer are operated by 12-Volt current from the tow vehicle. The brakes have been factory-calibrated for smooth, positive response. During the break-in period, brakes may squeak. This is normal, and will cease after a few miles.

### Brake System Components

**Tow Vehicle Battery.** This is the primary power source for the trailer braking system. The connection is made at the positive post of the battery, or at the tow vehicle starter solenoid battery terminal.

**Brake Controller.** The electric trailer brakes are automatically applied by the brake controller, which is usually mounted within easy reach of the tow vehicle driver. Some controllers are connected to the tow vehicle's hydraulic brake system, and are actuated when tow vehicle brakes are applied. Most experienced drivers prefer to have the trailer brakes set to engage slightly before those of the tow vehicle.

This is particularly helpful during rainy weather or slippery conditions. If the tow vehicle brakes first, the trailer will have a tendency to push the tow vehicle or possibly "jackknife." Lag time can be adjusted by turning the brake controller knob according to the instructions provided with the controller. The new setting will be retained until a new adjustment is made. Brake controllers usually have a manual feature, which allows you to apply the trailer brakes independently of the tow vehicle brakes. Connect the controller to the brakes with 12-gauge stranded wire.



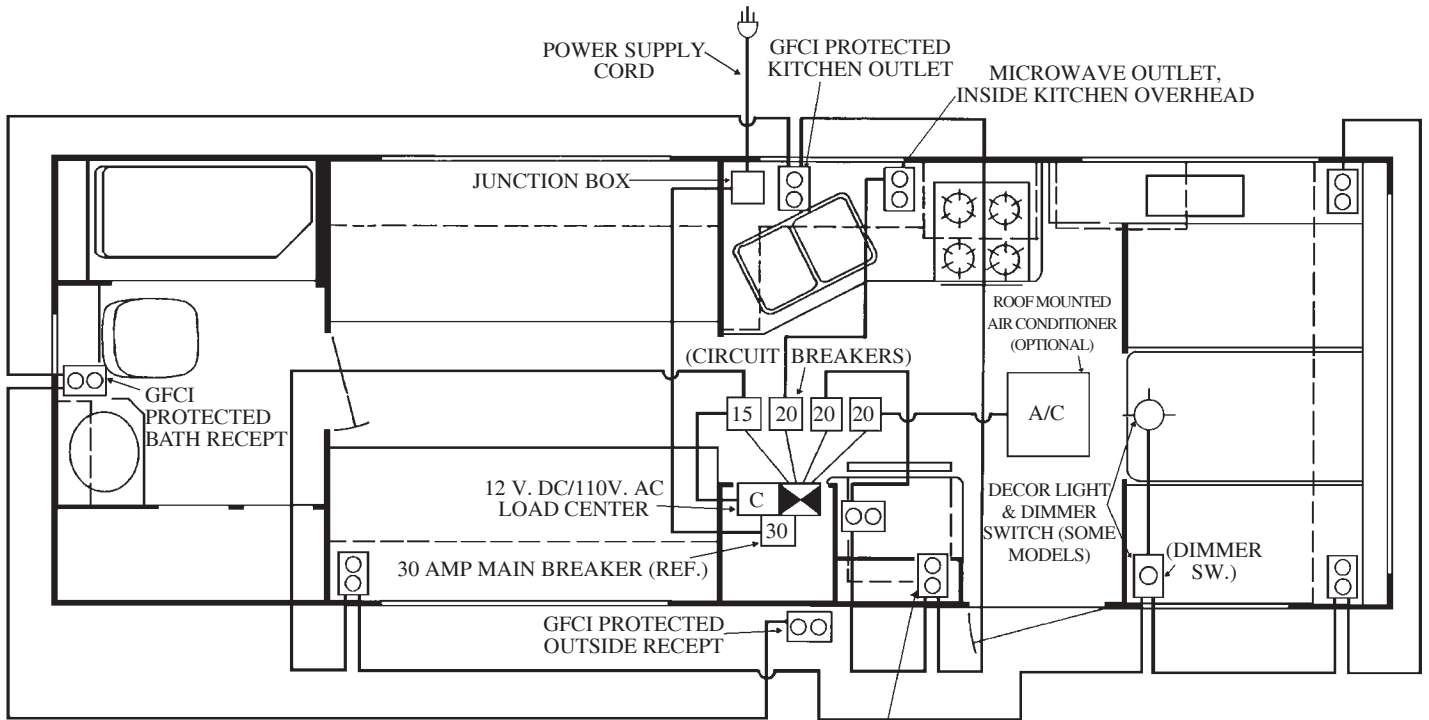

Typical 120 Volt Electrical System

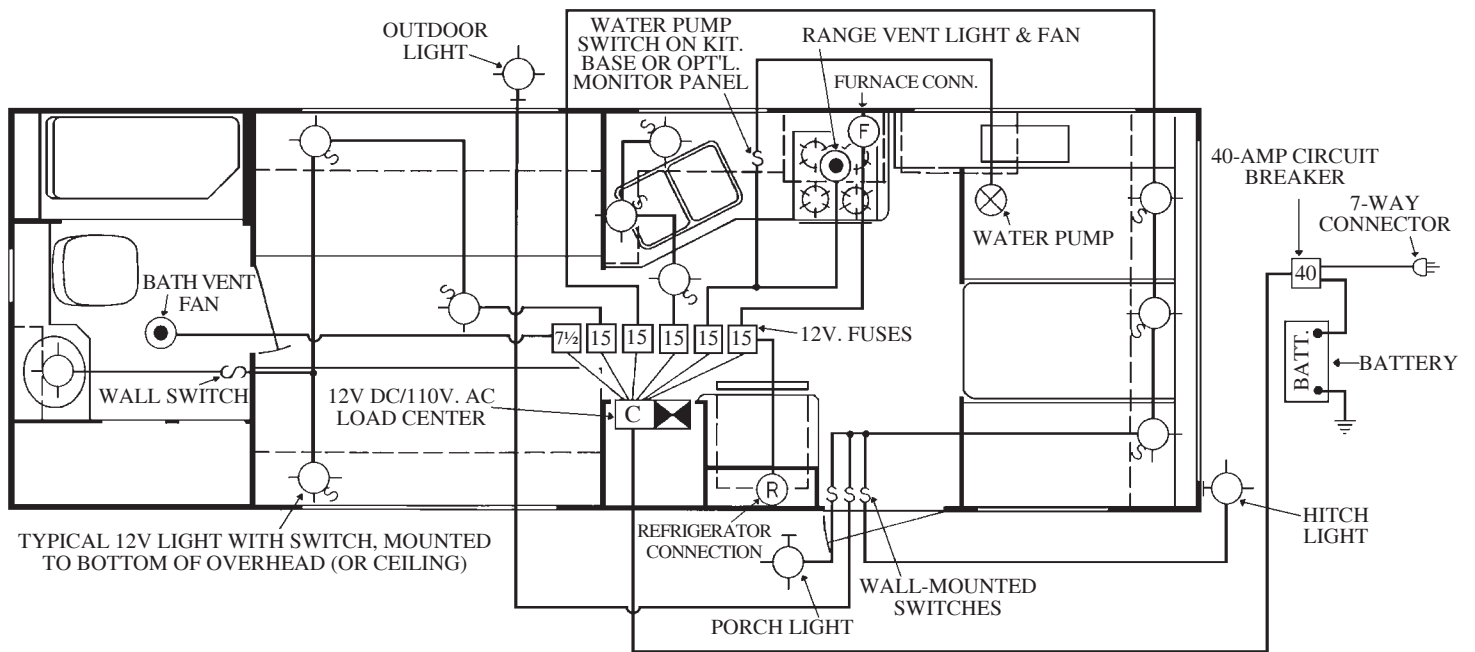

Typical 12 Volt Electrical System

## Chapter 6: Propane Gas System

### CAUTION

**THIS PROPANE PIPING SYSTEM IS DESIGNED FOR USE WITH PROPANE ONLY. DO NOT CONNECT NATURAL GAS TO THIS SYSTEM.**

Securely cap this inlet when not connected for use. After turning on propane, except after normal cylinder replacement, test propane piping and connections to appliance for leakage with soapy water or bubble solution. Do not use products that contain ammonia or chlorine.

### CAUTION

**PROPANE IS HIGHLY FLAMMABLE AND DANGEROUS. It is not poisonous, BUT WILL INDUCE DROWSINESS AND MAY CAUSE SUFFOCATION. Under ordinary circumstances, breathing small amounts should not be harmful. Use extreme caution — and see that others do — when filling the storage tank(s). There should be no flame or spark or anything which might induce a spark within at least 25 feet of the filling operation.**

### WARNING

**PROPANE POWERED APPLIANCES PRODUCE CARBON MONOXIDE. CARBON MONOXIDE CAN BE FATAL! WHEN THE DEVICE DETECTS CARBON MONOXIDE IN THE AIR IT WILL SOUND. CONSULT THE INDIVIDUAL DETECTOR'S USER MANUAL FOR SPECIFIC INSTRUCTIONS AND/OR AUDIBLE WARNING MEANINGS.**

### WARNING

**IF YOU SMELL PROPANE:**

1. EXTINGUISH ANY OPEN FLAMES, PILOT LIGHTS, AND ALL SMOKING MATERIALS.
2. DO NOT TOUCH ELECTRICAL SWITCHES.
3. SHUT OFF THE PROPANE CONTAINER VALVE(S) OR PROPANE SUPPLY CONNECTION.
4. OPEN DOORS AND OTHER VENTILATING OPENINGS.
5. LEAVE THE AREA UNTIL ODOR CLEARS.
6. HAVE THE PROPANE SYSTEM CHECKED AND LEAKAGE SOURCE CORRECTED BEFORE USING AGAIN.

**FAILURE TO COMPLY COULD RESULT IN EXPLOSION RESULTING IN SERIOUS INJURY OR DEATH.**

### WARNING

**PROPANE REGULATORS MUST ALWAYS BE INSTALLED WITH THE DIAPHRAGM VENT FACING DOWNWARD. REGULATORS THAT ARE NOT IN COMPARTMENTS HAVE BEEN EQUIPPED WITH A PROTECTIVE COVER. MAKE SURE THAT THE REGULATOR VENT FACES DOWNWARD AND THAT THE COVER IS KEPT IN PLACE TO MINIMIZE VENT BLOCKAGE WHICH COULD RESULT IN EXCESSIVE PROPANE PRESSURE CAUSING FIRE OR EXPLOSION THAT COULD CAUSE SERIOUS INJURY OR DEATH.**

Read all manufacturer appliance literature, including the information on the propane bottles and regulator, provided within the unit packet and follow any instructions given.

### General Information

Propane gas (also called LP, LPG or Liquefied Petroleum) when properly handled, is a clean burning dependable fuel for operating all propane gas appliances. The propane gas system involves the tank(s) (also called bottles or cylinders), regulators, valves, supply lines and appliances. Propane tanks contain liquid under high pressure, which vaporizes into a gas and passes through the regulator to automatically reduce the pressure. Low-pressure gas is then distributed through the supply lines to provide the fuel for propane appliances.

Consumption of propane gas depends upon the frequency and duration of use of the propane appliances. The refrigerator, range/oven, water heater and furnace all operate on propane. The furnace and oven have the highest consumption rates. During cold weather it is advisable to check the bottles often and always keep one full. Safety must be observed at all times when using the propane gas system. Propane gas is colorless and odorless in its natural state. A strong odorant, similar to rotten egg smell, has been added for consumer safety purposes to help detect leaks and provide warning.

Propane burns readily and yields a great deal of energy. Under proper conditions and careful handling, it is safe, economical, and ideally suited for use where conventional fuels are not easily utilized.

Your travel trailer heating, refrigeration, and cooking system are equipped to operate best on propane. Make sure your propane tanks are **NOT FILLED WITH STRAIGHT BUTANE**, which has a higher boiling point than propane. Butane will convert to a gas only at temperatures above 32 degrees Fahrenheit and will not function as a fuel below that. On the other hand, propane can be used as a fuel at temperatures down to -44 degrees Fahrenheit.

Both butane and propane are heavier than air. When released they flow downhill like water and will tend to fill depressions. Both diffuse readily and will dissipate quickly into the atmosphere if not allowed to be trapped in a depression or closed chamber.

### Propane Regulator

The regulator is the heart of the propane system. Propane gas is under high pressure in the bottle and the regulator reduces this pressure to less than one pound per square inch, to allow safe use with the appliances in recreational vehicles.

The lower pressure is distributed to the appliances. The arrow on the automatic gas regulator will always point to the gas bottle in service. When the red flag appears in the inspection glass, this indicates that bottle is empty. In systems without automatic changeover, the arrow should be then turned toward the other bottle and the empty filled as soon as possible.

### Care and Maintenance

The regulator has a vent that allows it to breathe. If pressure builds too high within the regulator, it vents until pressure reaches a normal range. Check the vent frequently to keep the vent clean and clear of any debris, corrosion or obstruction. A clogged regulator can result in higher pressures, loss of fuel and/or component failure. The vent can be cleaned by using a toothbrush and should be checked periodically by a qualified propane service center.

### Filling Propane Gas Bottles

Propane systems are equipped with a Type 1 cylinder connection, making them as easy to connect and disconnect as a garden hose.

The Type 1 connection system uses the Excess Flow Pigtail Hose, distinguished by the large green nylon swivel nut. The green swivel nut attaches to the outside of the cylinder valve with right hand threads. Tighten the swivel nut by hand. **DO NOT** use tools.

The safety features of this system prevent gas from flowing unless the connection is tight and will limit excessive gas flow. In cases of extreme heat, 240° to 300°F, at the connection, the connection to the cylinder will be shut down.

Procedure For Filling Propane Cylinders Equipped With An OPD Valve (Provided for information only — tanks must be filled by a qualified technician only)

1. Shut off tow vehicle and extinguish all appliance pilot lights when filling tanks
2. Ensure that the hand wheel valve is in the closed position

3. Attach the fill hose to the outlet on the valve
4. Turn on the propane source
5. Open the bleeder valve on the propane tank
6. Slowly open the cylinder bottle hand wheel valve approximately one-quarter turn
7. As the cylinder starts to fill, the hand wheel valve may be opened more. One turn is all that is necessary to complete filling the tank.
8. When the bleeder valve begins to spit liquid, shut off the propane fill source, close the bleed screw on the cylinder, then close the valve.

### Propane Gas Lines

The primary manifold is a black pipe located beneath the unit. Copper tubing, with flare fittings, is used as secondary lines running to the gas appliances. If repairs are needed to these lines or any component of the propane system, **DO NOT ATTEMPT** to repair yourself. Shut off the propane at the propane tank and have any necessary repairs made by a qualified service technician. Although your propane gas system was thoroughly inspected for leaks before delivery, gas fittings can loosen from vibration during travel. The propane gas system should be inspected at least once a year.

### Bleeding Air From Propane Lines

If the tank is completely emptied, it is possible that air has gotten into the gas lines. If this happens, you will probably find it difficult to light the pilots on the appliances. Air can be forced from the lines by lighting the appliance closest to the propane cylinders, and then the next closest, etc. This will cause the propane pressure to force the air out of the lines completely. You will find that pilots will not light as readily when air is escaping through them — be patient and they will light.

### Purging and Moisture Removal

All new containers (and in some cases used containers) may contain water, air, or other contaminants, and it is essential that these be removed before filling the container and placing it into service. Water vapor present in the gas vapor may cause regulator freeze-up at the inlet orifice and interrupt the gas service. Also, it may have an effect on the ability of the odorant to meet the present standards, as water can cause oxidation (rusting) on the inside of the container and result in “odorant fade.” Air in the container will cause abnormally high pressure, with the result that the pressure relief valve may open. Air in the system is also likely to cause pilot flames to go out and result in a service call. Additionally, air in the container carries moisture, which can cause service problems. If a container is suspected of being depressurized or open to the atmosphere for a period of time, it must be repurged as if it were a new container.

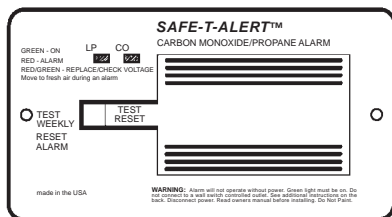

Carbon Monoxide/Propane Detector

### Propane Gas Leak Detector

Read the operating instructions, located in the unit packet thoroughly for the specific model installed in the unit.

The propane gas leak detector (sometimes combined in same unit with carbon monoxide detector) is a safety device that is permanently mounted near the floor and is powered by 12V (the RV battery and/or converter). The detector is operational only as long as sufficient battery power is available. If the power is disconnected, the monitor will not operate.

Should a propane leak occur, the detector will sound an alarm and continue until the gas has dissipated or until a mute button is pressed. The button will only stop the alarm from sounding for 60 seconds and will recur if gas is still present. The alarm may sound at times when no propane is present due to household product use such as aerosol hair spray, cleaners, adhesives, alcohol etc. Be sure to air out the trailer thoroughly when using these products and never allow them to spray directly on the detector.

The propane gas leak detector has a self-check circuit which runs at all times while receiving 12 Volt power. In the event that the circuitry fails, a failure alarm will sound and the operating indicator will cease to light.

### **! DANGER**

**DO NOT ATTEMPT TO ADJUST OR REPAIR REGULATOR. ADJUSTMENTS AND REPAIRS REQUIRE SPECIALIZED TRAINING AND TOOLS. CONTACT A QUALIFIED PROPANE SERVICE TECHNICIAN. FAILURE TO FOLLOW THESE INSTRUCTIONS COULD RESULT IN A FIRE, EXPLOSION AND/OR INJURIES, INCLUDING LOSS OF LIFE.**

### **! WARNING**

**DO NOT BRING OR STORE PROPANE CONTAINERS, GASOLINE, OR OTHER FLAMMABLE LIQUIDS INSIDE THE VEHICLE BECAUSE A FIRE OR EXPLOSION MAY RESULT.**

### **! WARNING**

**DO NOT FILL CONTAINER(S) TO MORE THAN 80 PERCENT OF CAPACITY. FAILURE TO COMPLY COULD RESULT IN A DEATH OR SERIOUS INJURY. OVERFILLING THE PROPANE CONTAINER CAN RESULT IN UNCONTROLLED PROPANE FLOW, WHICH CAN CAUSE FIRE OR EXPLOSION. A PROPERLY FILLED CONTAINER CONTAINS APPROXIMATELY 80 PERCENT OF ITS VOLUME AS LIQUID PROPANE.**

### **! WARNING**

**PROPANE CYLINDERS SHALL NOT BE PLACED OR STORED INSIDE THE VEHICLE. PROPANE CYLINDERS ARE EQUIPPED WITH SAFETY DEVICES THAT RELIEVE EXCESSIVE PRESSURE BY DISCHARGING PROPANE TO THE ATMOSPHERE. FAILURE TO COMPLY COULD RESULT IN DEATH OR SERIOUS INJURY.**

**WARNING**

PROPANE GAS MAY BE PRESENT IN OTHER AREAS BEFORE IT CAN REACH THE DETECTOR'S LOCATION. THE DETECTOR ONLY INDICATES THE PRESENCE OF PROPANE GAS AT THE SENSOR. NEVER CHECK FOR LEAKS WITH OPEN FLAME. USE ONLY A MILD SOAP AND WATER SOLUTION.

**When To Test Detector**

Testing of the detector is recommended every week, if power is interrupted or before each camping trip. The propane detector must be operating for at least 60 seconds before it can be tested.

**When The Alarm Sounds . . .**

- Open all doors and major windows.
- Turn off the gas supply at the propane tank.
- Do Not re-enter until alarm stops sounding.
- Turn on gas supply.
- If alarm sounds a second time, turn the gas off and contact an authorized dealer or propane service technician.

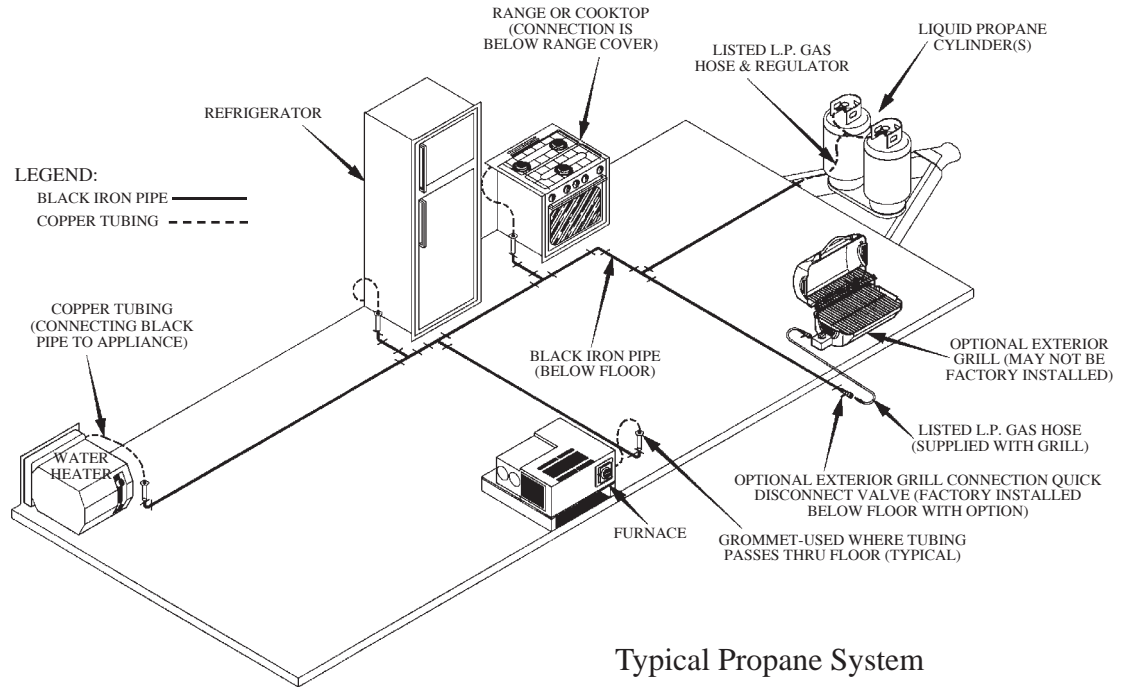

**Chapter 7: Plumbing System**

A recreational vehicle plumbing system consists of two sub-systems: The fresh water system and the wastewater system.

**Water System**

You can now have clean, fresh water anywhere you go with a minimum of trouble and difficulty. This is due, more than anything else, to modern developments in plastics. Your water tank and fresh water lines, as well as the drain lines, are made of durable, tough, lightweight plastic which are impervious to the corrosion and chemical reactions of other materials. They are clean and highly leak resistant.

Potable fresh water is supplied by either the fresh water tank aboard the unit or from an outside source connected through the city water connection. When using the fresh water tank, the water is pumped through the water lines by means of the water pump. When utilizing an exterior source, such as a campsite water supply, the pump is not needed as the water is already pressurized and will flow through the water supply lines within the trailer.

**Water Pump**

The 12 Volt water pump installed is self-priming and totally automatic, operating upon demand. When a fixture is opened, the pump draws water from the tank and pressurizes the lines, providing water to the open fixture. The pump has an on/off switch and is located on the monitor panel. DO NOT turn on the pump if the fresh water tank is empty.

**Before Turning On The Pump Switch**

1. Check the water level in the fresh water tank — if empty, refill. (See “Fresh Water Tank Fill”)
2. Open kitchen and bathroom faucets, hot and cold valves, and any shower/tub fixtures.
3. Check to make sure Water Heater By-Pass Valve is set to “Normal Flow” to allow water into the hot water heater.

**CAUTION**

Never let the water pump run while the fresh water tank is empty. Damage to the pump and/or a blown circuit may occur.

4. Turn on switch for water pump and allow the pump to fill the water lines and hot water heater tank.
5. Close each faucet after it delivers a steady stream of water.
6. The water pump should stop running after all faucets are closed.
7. Pump should now run on “demand” when a faucet is opened, and stop when the faucet is closed.

While away from your travel trailer or while sleeping, the pump should be switched OFF in order to avoid having it run unnecessarily.

If any of the listed conditions arise, try the following step-by-step procedures. If these do not solve the problem, consult a service center.

1. Pump will not prime (it should do this automatically):
  - a. Check to be sure that there is water in the tank.
  - b. Check to be sure that the battery is not run down.
  - c. Check water pump fuse.
2. Pressure drops:
  - a. Check faucets and connections for leaks.
  - b. Check to be sure faucet aerators are clean.
  - c. Check to be sure there is water in the tank.
  - d. Check to be sure that the battery is not run down.
  - e. Check storage tank vent.
3. Pump runs when there is no apparent demand for water:
  - a. Check all faucets and fixtures to make sure they are shut off and not leaking.
  - b. Check to be sure there is water in the tank.
  - c. Check lines for leaks.

### Fresh Water Tank

A fresh water tank is equipped on all travel trailers and fifth wheels. Tanks vary in size according to product and model. To determine how much fresh water the system can hold, refer to the RV Trailer Cargo Carrying Capacity label located on the inside of the front curb side entry door. (See page 13 for more information)

The full capacity rating of fresh water for the travel trailer/fifth wheel includes the cumulative total of the tank, lines and the hot water heater tank.

### Fresh Water Fill

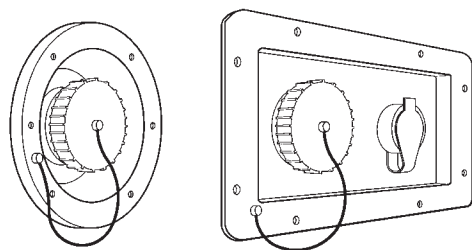

To fill the fresh water tank, remove the cap, on the exterior connection labeled “Fresh Water Connection” or “potable water only”, and insert a garden hose. Check the monitor panel to determine the level of water in the tank during filling. When full, water may spill out back through the opening, as there is no automatic cutoff. When filling the fresh water tank it is a good idea to also fill the hot water heater and lines to provide the maximum system capability.

When traveling with the water tank full, the cargo carrying capacity is reduced.

Water should be drained from the fresh water system when not in use for more than one week.





## City Water Fill

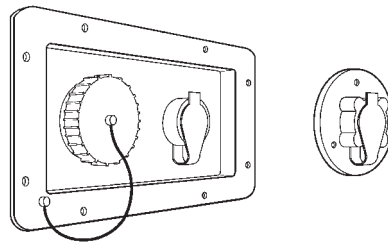

The city water fill allows a direct connection to an outside source, such as campsites with water risers. There is no need to use the water pump as the water coming from the exterior source is already pressurized and will bypass the pump and tank. This connection has a sanitary plastic cover for protection when not in use. Connect the city water fill by using a hose manufactured for potable water use. Open faucets and allow any air to be purged.

City water fills are marked with a label and may be installed as a separate piece of equipment or as a part of a combination water inlet housing.

## Sanitizing the Fresh Water System

Keeping the fresh water system clean and free of any potential contaminations is a top priority. Sanitizing the system before initial use and thereafter annually, or whenever water remains unused for prolonged durations, is recommended. This will help keep the water system fresh and discourage harmful bacterial or viral growth. To sanitize your system, perform the following:

1. Drain the tank by opening the low point drain for the fresh water tank. Make sure water heater is not by-passed.
2. Prepare a chlorine bleach solution of  $\frac{1}{4}$  cup to one gallon of water for every 15 gallons of tank capacity.  
Example: Use  $2\frac{3}{4}$  gallons of the solution for a 40-gallon tank. If using Ultra bleach concentrations, reduce bleach to  $\frac{1}{8}$  cup to one gallon of water.
3. Add solution to tank and fill with water. Turn on pump and open each faucet/fixture until a distinct chlorine odor is smelled. Close faucets and let stand 4 hours. Do not forget to turn on hot water taps as well as cold.
4. Completely drain system and flush with fresh water until chlorine odor and smell is gone. (If water filter has been added, change it at this time).

## About Vibration While Traveling

The fresh water system was thoroughly inspected for leaks before delivery. However, vibration during travel can loosen fittings. Periodically check the fittings at the faucets and visible connections and tighten when necessary.

## Water Heater

Carefully read the manufacturer's manual for complete operational and safety instructions, provided in the unit packet, prior to using the appliance.

The water heater in your trailer operates on propane, and is similar to the one in your home. It contains an automatic shut-off valve which stops the gas flow if the water temperature rises too high. The water heater is reached through an access panel on the outside of the trailer.

The water heater installed is typically a 6-gallon (standard) or 10-gallon (optional on some units). Dependent upon the model installed, the water heater will operate only on gas or on either gas or AC current.

If an electric water heater is installed, the water heater circuit breaker must not be turned on until the water heater tank is completely filled. To fill tank, turn on the hot water faucet at the galley sink. If water flows continuously, the heater is full. Tank must be filled with water prior to operating any type of water heater.

## Pilot Models

To light the pilot light on your gas water heater, first open the propane bottle's service valve. Turn the water heater gas cock knob to the OFF position. ALWAYS wait five minutes to allow propane which may have collected in the burner compartment to dissipate. Then turn the gas cock knob to the PILOT position and ignite. After 30 to 60 seconds, turn to the ON position. (Refer to water heater instruction manual.)

### WARNING

A CONTAMINATED WATER SUPPLY CAN CAUSE SERIOUS INJURY OR DEATH.

### CAUTION

DO NOT OPERATE THE WATER HEATER UNTIL IT IS FILLED WITH WATER.

### WARNING

HYDROGEN CAN BE PRODUCED IN THE WATER HEATER SYSTEM IF THE HEATER HAS NOT BEEN USED FOR A LONG TIME, GENERALLY TWO WEEKS OR MORE. THIS IS ESPECIALLY TRUE IF THE WATER HEATER HAS BEEN DRAINED. HYDROGEN GAS IS EXTREMELY FLAMMABLE. DUE TO THE RISK OF SERIOUS INJURY OR DEATH UNDER THESE CONDITIONS IT IS RECOMMENDED THAT THE HOT WATER FAUCET BE OPENED FOR SEVERAL MINUTES AT THE KITCHEN SINK BEFORE USING ANY ELECTRICAL APPLIANCES. IF HYDROGEN IS PRESENT THERE WILL PROBABLY BE AN UNUSUAL SOUND, LIKE AIR ESCAPING THROUGH THE PIPE AS THE WATER BEGINS TO FLOW. THERE SHOULD BE NO SMOKING OR OPEN FLAME NEAR THE WATER FAUCET WHEN IT IS OPENED.

### Electronic Ignition Models

If your water heater is equipped with an electronic ignition, place the switch in the ON position. If the switch light comes on, place the switch in the OFF position and wait five minutes before proceeding. After the required delay, again place the switch in the ON position.

To completely shut down the unit, place the switch in the OFF position. It may take more than one attempt to start when the unit is being used for the first time or after the refill of the propane tanks.

### Care and Maintenance

Proper maintenance of the water heater relies on inspection and awareness. *(Full maintenance requirements are listed within the manufacturer's user's manual located in the unit packet.)* An anode rod within the tank increases the life of the tank and under normal use will deteriorate. Replacement of the anode rod should be done yearly or more frequently if water supplies contain high levels of iron or sulfate. Another important maintenance procedure is periodically checking the water heater screen in the exterior door for any obstructions, such as animal/insect nests or debris. Proper ventilation is essential to the safe operation of the water heater.

A qualified technician should do any repairs that need to be performed. If soot is present anywhere, immediately shut the unit down and contact a qualified service technician. Soot is a sign of incomplete combustion and must be corrected before operating the water heater.

### Pressure Relief Valve - Weeping or Dripping

As in residential water heaters, the water heater equipped in recreational vehicles contains a pressure relief valve, located behind the exterior water heater door. It is designed to open if the temperature of the water within reaches 210 degrees F or if excessive pressure is built up. When pressure reaches 150 pounds, the relief valve will open and water will drip from the valve. The valve will close automatically once the pressure falls below 150 pounds. This dripping is normal and does not indicate a malfunctioning or defective valve.

Also, as water is heated, it expands and with the closed water system in a recreational vehicle, water expansion will cause weeping at the pressure relief valve. One way to minimize this weeping is by maintaining an air pocket at the top of the water heater tank. The air pocket forms naturally by design but will reduce overtime through normal use.

#### Replenishing the Air Pocket

1. Turn off water heater.
2. Turn off cold water supply.
3. Open a faucet in the RV.
4. Allow time for water to cool and pull out handle of the pressure relief valve and allow water to flow from the valve until it stops.
5. Release handle on valve-it should snap shut.
6. Close faucet and turn on cold water supply. As tank fills, the air pocket will be replenished.

### Water Supply and Odor

Water supplies sometimes contain high levels of sulphur, which causes an unpleasant smell, similar to rotten eggs. While unpleasant, the water is not harmful. Sanitizing the water system, as described earlier and allowing the sanitizing solution to remain for a few days, should eliminate the odor. Remember to thoroughly flush the system after sanitization. Adding a filtration system will help reduce such occurrences.

### Draining and Storage

When not using for long periods or storing during the winter months, the water heater must be drained to avoid damage from freezing during the winter and/or deterioration of tank life from mineral content in water supplies.

#### To Drain the Water Heater

1. Turn off power to the water heater at the switch or the main breaker.
2. Shut off the gas supply and the water pump.
3. Open all fixtures, both hot and cold throughout the unit.
4. Place the bypass valve (if equipped) in the "by-pass" position.
5. Remove/open the exterior access door to the water heater.
6. Remove the anode rod from the tank. Water will drain out tank.



### By-Pass Kit (Optional)

The by-pass kit is a popular convenience feature that allows for easier drainage of the hot water heater tank and winterization of the unit. The by-pass kit is installed near the water heater and allows for blockage of water flow into the water heater, saving time and reducing the amount of anti-freeze needed during winterization.

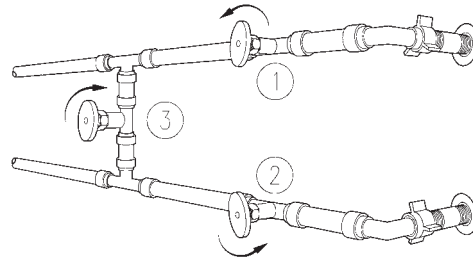

Back of Water Heater

To by-pass water heater close valves 1 & 2, open valve 3. To use water heater close valve 3, open valves 1 & 2.

### Monitor Panel

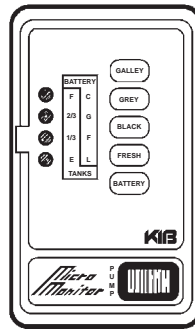

The monitor panel allows you to check the approximate liquid levels in the fresh water and the gray and black holding tanks. Dependent upon the type of monitor panel, 3 or 4 tanks can be monitored along with the charge condition of the battery. The monitor panel shown is typical; the one in your unit may look and function differently. Be certain your dealer explains the operation of the monitoring panel in your unit.

### Operation

Depress the button for the desired reading (tank or battery.) The levels readout for the tanks will read at Empty (E), 1/3, 2/3, or Full (F). All lights will be lit when full. The battery conditions are as follows:

- C Charge
- G Good
- F Fair
- L Low

### Erroneous Readings

The monitor panel displays readings from sensors attached to the tanks. These sensors can send false readings when the following conditions occur:

1. Water with low mineral content. Minerals in water help conduct the electrical signal to the monitor display. Some water, which is very low in mineral content, may not conduct the signal properly. Although infrequent, this condition can exist. Check the panel reading when the fresh water tank is filled.
2. Material trapped on the sides of the holding tanks also may provide full readings when the tank is actually empty. Use of a spray to wash out the tank following dumping should help prevent this condition.
3. Grease build up on the sensor probes may indicate false readings or no readings at all. Avoid pouring any grease, oils or similar substances down drains or the toilet. If this occurs, wash the tank(s) out with soapy water.

### Winterization

RV components can be damaged from the effects of freezing. Protection of the plumbing system and related components is crucial. Damages due to weather are not covered under warranty at any time.

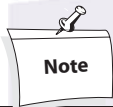

Note

For Winterization Procedures, See the section "Winterization" in this chapter.

Many recreational vehicle owners choose to have their units winterized by their dealer, while others choose to do it themselves. Following are descriptions of two methods used to winterize:

### 1. Compressed Air (Dry) Method

Uses compressed air to blow out any remaining water in the system after draining the system of all water. This method requires an air compressor and appropriate adapters.

### 2. RV Anti-Freeze (Wet) Method

Uses RV approved, nontoxic, potable, anti-freeze in the system and does not require any special tools.

Many Skyline products include an optional by-pass kit that allows the plumbing system to bypass the hot water heater, reducing the amount of anti-freeze that will be needed (by-pass kits are available at most RV service centers for a reasonable expense and can be installed during winterization). Without a by-pass kit installed, an additional 6 - 10 gallons of anti-freeze will be required.

Following are procedures for both methods. Your local dealer is best suited to answering any questions as well as providing information on winterization and storage that may be particular to the climate in your area.

If using the compressed air method, a special adapter should be purchased to allow compressed air to be delivered through the city water fill. These adapters are available at most RV supply stores.

#### **Method 1**

Compressed Air (With By-Pass Kit Installed)

1. Purchase 1-2 gallons of RV non-toxic anti-freeze.
2. Drain the fresh water tank and empty the waste water holding tanks.
3. Turn water heater by-pass valve to by-pass position. (The by pass valve is located near the water heater incoming lines — an access panel may have to be removed depending upon the model.)
4. Drain water heater.
5. If installed, remove water filter from assembly and discard. Install diverter if included.
6. Open all faucets, including shower head sprayer, toilet flushing device and any other water lines that are closed.
7. Turn on the water pump for 30 seconds to clear out any water in the lines.
8. Connect an air hose with an adapter to the city water fill connection.
9. Set the pressure no greater than 30 pounds and blow out the water lines until no water can be seen coming out of the fixtures and lines.
10. Pour RV anti-freeze into drains, p-traps, toilet, and tanks.

#### **Method 2**

RV Anti-Freeze (With By-Pass Kit Installed)

1. Purchase 4-6 gallons of RV approved, non-toxic anti-freeze.
2. Drain all tanks, fresh water and sewage tanks.
3. Turn water heater by-pass valves to by-pass position. (The by pass valves are located near the water heater incoming lines — an access panel may have to be removed depending upon the model.)
4. Drain water heater.
5. If installed, remove water filter from assembly and discard. Install diverter if included.
6. Pour an amount of RV non-toxic anti-freeze into the fresh water tank to fill the tank above minimum water pump operating level. (Use of a long funnel may be helpful) Add more, if necessary, during procedure.
7. Turn on pump switch and open the cold water side of all faucet fixtures. Leave open until the anti-freeze comes out (generally, pink in color). Repeat for hot water side.
8. Flush toilet until anti-freeze begins to flow into the bowl and then pour one gallon of anti-freeze down the toilet to winterize the black tank.
9. Pour anti-freeze down each shower/tub, lavatory sink, and kitchen sink to fill p-traps.
10. To winterize gray tank(s) pour one gallon down each related sink drain.

#### **De-winterization/Removal of Anti-freeze**

If purchasing a trailer which is winterized with RV anti-freeze, or having had an existing unit winterized before winter storage, the plumbing system must be flushed and sanitized prior to use. Do Not Attempt to turn on water heater if system is winterized. Perform the following prior to attempting to operate the water heater or use the plumbing system.



**⚠ DANGER**

**DO NOT USE AUTOMOTIVE ANTI-FREEZE. AUTOMOTIVE ANTI-FREEZE IS POISONOUS AND NOT FOR USE IN POTABLE WATER SYSTEMS.**

1. Drain fresh water tank.
2. Attach garden hose to fresh water fill and fill tank.
3. Turn on pump switch and open cold water side of all faucet/shower fixtures. Leave open until water runs clear. Repeat for hot water side.
4. Flush toilet until clear water runs into bowl.
5. Empty fresh water tank. (And holding tanks as necessary)
6. Sanitize water system. (See earlier section in this chapter)
7. If a water filter is installed, drain lines, remove filter assembly, clean and reinstall with new filter.

### Waste Water System

The wastewater system inside the recreational vehicle is self-contained while on the road or set up in a campsite. The main parts of the waste system are the toilet, holding tanks and tank dump valves. As in residential households, the drainage system also includes p-traps and roof vents to allow escape of odors and gases.

### Toilet

The toilet operates from water supplied either by the fresh water tank or from an exterior water supply connected at the city water hook-up. (The water pump must be turned on when utilizing the water from the fresh water tank.) The toilet flushes directly into the black water tank. Complete instructions and care for the model installed are located in the unit packet.

### Solid Build-Up

The most common problem associated with the waste system is solid build up. Using plenty of water when flushing the toilet, and keeping the tank valves closed until ready to flush the system can reduce the risk of build up. Should you ever have a build up of solids, close the valves, fill the tanks about ½ full with fresh water and small amount of liquid detergent then drive a distance to agitate the solids before draining the tanks at an approved disposed location.

### Do not put these items in toilet or drains

1. Facial tissues, paper towels, sanitary products (including those labeled flushable).
2. Detergents or bleach. Use a sewage tank deodorizer, available from dealer.
3. Automotive antifreeze, ammonia, alcohols, or acetones.
4. Grease from cooking, table scraps or other solids that may cause clogging.

### Holding Tanks

Waste water is divided into two categories: *Black water* and *gray water*. The term black water refers to the waste flushed down the toilet and stored in a separate tank, or referred to as the *black tank*. Gray water is the wastewater from the sinks, tub and shower drains and is stored within one (or more) *gray tank(s)*. Waste tanks empty through a single outlet, but a separate valve controls each tank.

The dump valves should remain closed even if connected to an exterior sewer hook up. For proper dumping, empty tanks only when they are nearly full. The idea is to send a large volume of water through the tanks and hose at the same time to assist the solid waste in flushing from the system. Otherwise solids may build up and harden inside tank.

### Dumping Instructions

1. Be sure unit is reasonably level so tanks can fully drain.
2. Twist off the termination outlet cap.
3. Connect the sewer hose by turning clockwise, locking the end levers over the termination end.
4. Place the other end of the sewer hose into an approved dump station inlet.
5. Open the black tank termination valve and drain. (Always dump black tank first so gray water washes out hose)
6. You may want to close the black tank valve and refill tank half full by engaging the toilet flush valve. Then open the termination valve for the black tank, dumping it again.
7. Open the gray tank termination valve and drain. (If unit has 2 gray tanks, drain one at a time.)\*
8. Close termination valves, making sure they are in locked position.
9. Disconnect sewer hose and store.
10. Replace termination cap on the outlet.
11. Add chemical deodorant/breakdown agent approved for RV use.

*\*If unit is equipped with the No-Fuss Flush System, perform flush at this time.*

After the sewage tank has been emptied, close the gate valves and put approximately five gallons of water in the sewage (black water) holding tank. This will help prevent solids from building up. The addition of a deodorizing agent like Aqua-Kem® will help prevent odors.

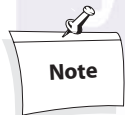

#### Note

Termination cap must be in place at all times except when connected to sewer.



### No Fuss Flush (Optional)

If equipped, the no fuss flush kit has been installed to rinse the interior of the black tank. Similar to the water fills located on the exterior of the unit, a separate hookup is placed on the exterior.

Flush the tank after dumping by connecting the sewer hose and attaching a garden hose\* to the inlet labeled “Sewer Valve Must be Open When Using This Inlet” OR “Black Tank Flush.” Open the water supply to full pressure to flush tank. When water runs clear from sewer hose, shut off water supply and disconnect garden hose from source. Do not disconnect hose from flush inlet until water has drained from system.

\* Be sure to have separate garden hoses for potable water filling and black tank flushing.

### Troubleshooting Tips For The Drainage Systems

If the toilet will not flush:

1. Holding tank may be full and need dumping, or toilet needs mechanical servicing.

If sink will not drain:

1. Drains may be clogged. Use a good plunger or remove and clean the drain trap.

If holding tank will not dump or only partially dumps:

1. Be sure unit is level before dumping.
2. Waste may have solidified and clogged drain valve. Partially fill tank with water and soap and tow unit for about 10 miles. Surging motion of soapy water in tank should loosen the solid matter and allow dumping. Always rinse tank thoroughly after dumping.
3. Check handle on slide dump valve to be sure it is operative.

For problems with marine toilet, consult manufacturer’s manual.

### Toilet

Your trailer is equipped with either a hand control lever or foot pedal operated marine-type toilet.

#### To operate the hand lever control model:

- To flush, pull the black lever located on the right side of the toilet forward until rinse water clears the bowl, then slowly release the lever.
- The water fill lever (white lever) can be operated independently of the flush to adjust the level of water in the bowl.

Typical Hand Control Marine-Type Toilet

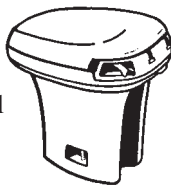

Flush Lever



Water Lever

#### To operate the foot pedal model:

- Depress the small pedal to add water to the desired level, then slowly release the pedal.
- To flush, depress the large pedal until the rinse water clears the bowl, then slowly release the pedal.

Typical Foot Pedal Marine-Type Toilet

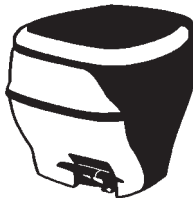

Water Pedal



Flush Pedal

If your trailer is equipped with a toilet other than these models, please follow the operating instructions provided.

### Toilet Maintenance

The toilet does not require any routine maintenance. Clean the unit with a high grade, nonabrasive cleaner. DO NOT use highly concentrated or high acid or alkaline household or toilet bowl cleaners. These products can damage the finish and valve components in the flush seal.



## Toilet Troubleshooting

### Water Keeps Running Into the Bowl

- On the hand lever models, be sure the levers return all the way. If they do not, there may be foreign matter on the waste blade valve or the seal in the bottom of the bowl preventing the bowl from fully closing.
- On the foot pedal models, clean out any foreign material in the groove where the valve blade seats in the bottom of the bowl.

### Foot Pedal Hard To Operate or Blade Sticks

- Spray a light film of silicone on the blade.

### Poor Flush

- The lever or pedal must be held fully open during the flushing for two or three seconds.
- Be sure a sufficient quantity of water is in the bowl to carry waste into the holding tank.

### Toilet Leaks, Water On Floor

- Check the water inlet connection. Tighten, or clean and tighten if necessary.
- Refer other toilet leaking conditions to an authorized Skyline dealer.

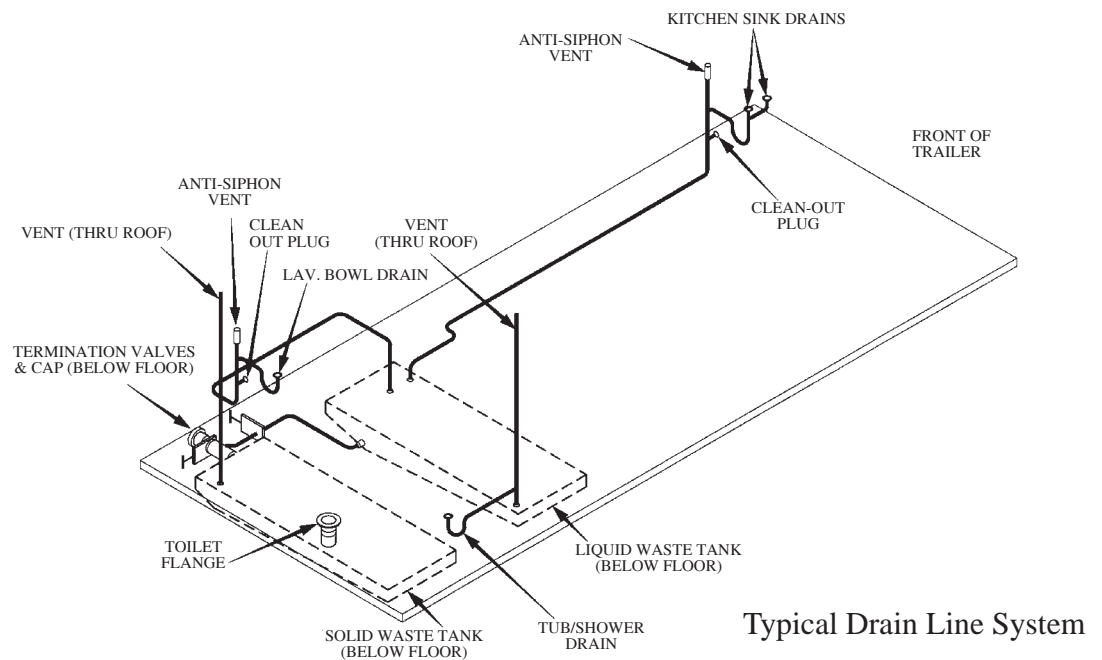
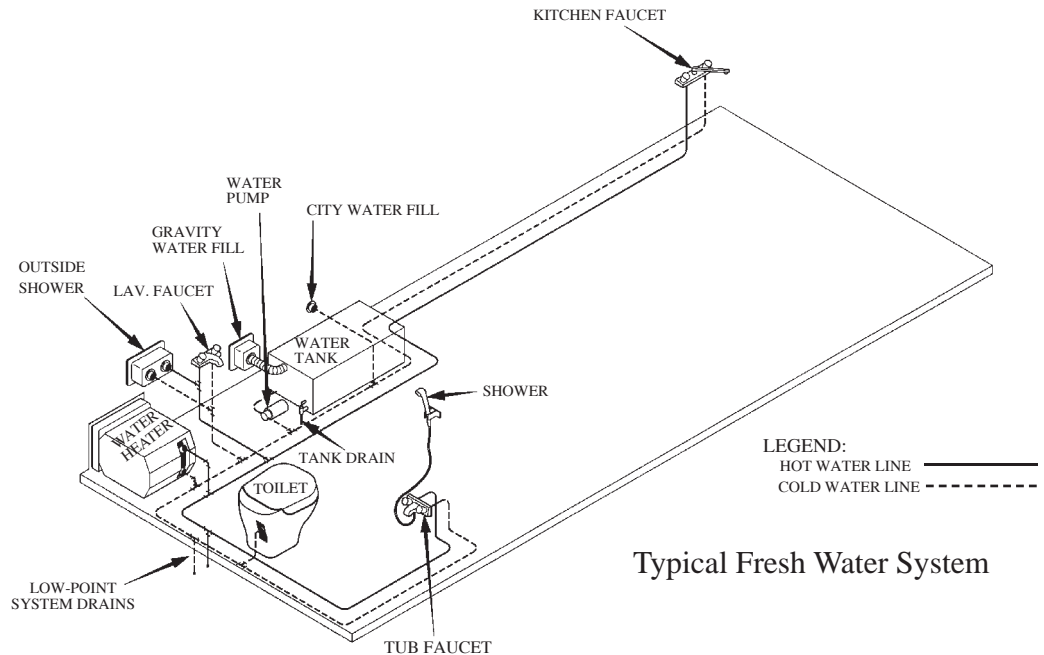

# Travel Trailer and Fifth Wheel Slide-Out Room Adjustment and Operation

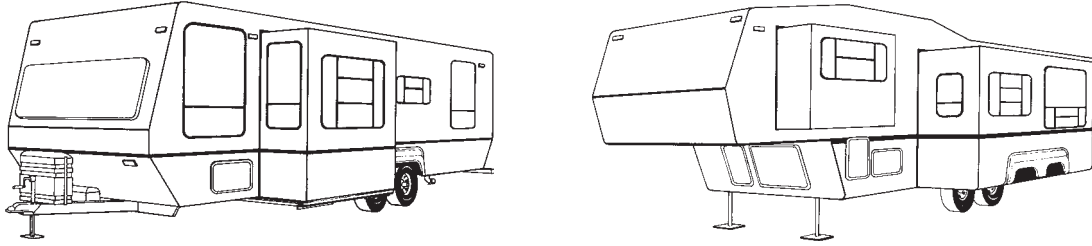

## Chapter 8: Slide-Out Systems & Ramp Doors

This section covers the recommended setup procedure and operation of slide-out rooms which are available in Skyline trailers. **FAILURE TO CAREFULLY FOLLOW THESE INSTRUCTIONS COULD CAUSE AN UNSAFE CONDITION THAT MAY RESULT IN SERIOUS INJURY OR DEATH.** Your trailer and factory slide-out assembly were designed as a unit; thus, satisfactory performance of both is contingent on the correct setup procedure as follows:

Prior to extending the slide-out room, the trailer must be unhitched from the tow vehicle and the trailer must be in its final level position. (See leveling procedures on Pages 23). It is highly recommended to use stabilizing jacks or jack stands as mentioned in the section Towing and Leveling. Travel locks may be installed either on the top or sides of the slide-out room to stabilize the room during transit. If installed, they must be removed prior to operation. Be sure that nothing will interfere with the room movement and that all people are kept clear.

The slide-out room operates on a 12-volt system. The 12-volt system is protected by a 12-volt circuit breaker. The electrical system must have a fully charged 12-volt battery in the wiring system prior to operating the slide-out. **DO NOT OPERATE THE SLIDE-OUT ROOM WITH THE CONVERTER ONLY. DAMAGE TO THE SLIDE-OUT MOTOR WILL OCCUR.**

To operate the 12-volt electric slide-out, locate the switch near the slide-out room. The switch is spring-loaded and will return to the OFF position when released. To extend or retract the slide-out room hold the switch until it reaches its final position then release the switch. Familiarize yourself with the direction of travel of the room and the corresponding switch direction.

If the slide-out mechanism does not operate due to loss of power or electrical failure, the slide-out room may be moved manually. Please refer to slide-out room manual in owner's packet for instructions to operate room manually.

### Basic Slide-Out Tips

Ensure that your batteries are properly maintained and fully charged to avoid problems associated with low voltage. Limit the amount of 12 Volt lights and appliances in use when operating slide-rooms.

The recreational vehicle must be level to avoid binding the slide-rooms. Remember, leveling jacks are not capable of supporting the weight of your vehicle! They are intended only to stabilize the unit maintaining a level condition. Non-leveled conditions cause sticking situations and damaging strains on the slide-out mechanism.

Weather and atmospheric conditions will in time cause rubber to deteriorate. The seals around slide-rooms should be regularly inspected and replaced at the first sign of a problem. Professional setup and adjustment, regular maintenance and replacement of weather seals will greatly extend the life of the unit. Weather seals which are allowed to remain in service after deterioration will allow rain, snow, or ice to penetrate the roof and walls and will cause extensive damage. Inspect the seals twice a year and look closely for sign of cracking or damage. This maintenance is the owner's responsibility and is not covered beyond the terms of the unit warranty.

### **WARNING**

**BEFORE OPERATING THE SLIDE-ROOM, ASSURE THERE ARE NO OBJECTS (OR PEOPLE) IN THE PATH OF THE ROOM.**

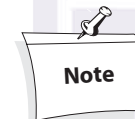

### **Note**

**On sofa slides, it may be necessary to remove an access panel below the sofa to gain access to slide out mechanism.**

## Slide-Out Room Adjustment

Slide-out rooms, which are available in many Skyline trailers, are adjusted at the factory and should not require readjustment. However, if adjustment is needed this section covers the basic techniques. If you do not have adequate training or experience in adjusting slide-out rooms, consult someone who has experience and ask them to adjust the slide-out room. If you have any doubt, contact your dealer, the factory, or Skyline's Director of Consumer Relations as outlined in this manual before trying to adjust your slide-out room.

The slide-out room may be adjusted in three directions: the height, length of travel, and front to back. It may be necessary to adjust the room in one direction or any combination of directions. **THE TRAILER MUST BE LEVEL PRIOR TO ADJUSTING THE SLIDE-OUT ROOM.**

### Length of Travel

The length of travel of the slide-out room (electric motor driven) may require adjusting if:

- A) the entire slide-out room does not fully extend, or
- B) the entire slide-out room does not close completely when retracted.

Please refer to slide-out room manual in owner's packet for instructions.

### Front to Back / Height

The slide-out room has been adjusted from front to back and for height and should not require readjustment. Trying to adjust your slide-out may result in damage to the slide-out mechanism. However, if adjustment is needed, contact your dealer, the factory, or Skyline's Director of Consumer Relations as outlined in this manual.

### Electrically Operated Systems

Basically, all electric slide out systems use a 12 Volt DC motor to power the rack and pinion style slide system room(s). Electricity for the motor assembly is supplied by the trailer battery. Normal operation is performed by pressing the wall mounted slide-out switch to extend or retract the room.

### Care and Maintenance

When operating the Lippert Electric Slide-out System™ it is recommended that the moving parts be kept clean, especially when operating in harsh climates or environments. Road salt, ice, sand, and salt water climates are examples of such conditions. The moving parts can be washed with a mild soap and water solution. Slide-out care does not require any grease or lubrication.

### Electrical Maintenance

Electrical maintenance is also essential to the smooth operation of the slide-out system. Full battery current and voltage is essential for optimum performance. Regularly check the terminals of the battery, the control switch and the motor. Look for signs of any corrosion of loose or damaged terminals and connections from environmental conditions, as well as road debris and vibration.

### Manual Crank Option

All electric slide-out systems come with a manual override system. This option can be utilized in case of power interruption or system failure. Detailed instructions on using this option can be found in the manual for this slide-out system.

### Rear Slide-Out Bed Set Up (see Illustration on page 53)

Prior to setting up room it is essential that the main unit first be level. See instructions in owner manual section on leveling for leveling main unit.

1. Remove the slide-out room guides from storage and unfold them.
2. Insert the top leg of the guide into the latch (# 2) making sure the guide is fully engaged in the lock, then insert the lower leg of the guide into its respective latch (# 1). Do the same with the second slide-out room guide.
3. Level the top of the guide from front to rear and across the two guides. To level the guide, release the lower leg from the latch and turn the end. Looking toward the latch, turning the end of the leg will raise the rear most part of the guide. Turning it counter clockwise will lower the rear most end of the guide.
4. Tighten the stop nut on the lower leg so this position will be maintained for future use. You may want to label the guides right and left so they can always be used on the same side, reducing the time to level them the next time. However, they still must be checked for level each time the room is set up to ensure easy operation.
5. Release the room latch on both sides by pushing in then down and out of the catch.

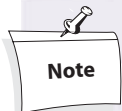

#### Note

During extended travel stays, move the room in and out once or twice a week to help keep the seals and internal moving parts lubricated.

During long-term storage periods, it is advised to have the room retracted.

6. Using the handles pull the room out onto the guides. The room will stop when it is fully extended.
7. Go inside and lock the room in the out position by swinging the locking foot up over the locking angle (see # 7). Turn the locking screw knob handle until a moderate pressure is attained.
8. Plug in the 12 Volt power cord on the inside at the bottom of the room opening.
9. The room is now ready to use. Reverse the procedure to retract the room.

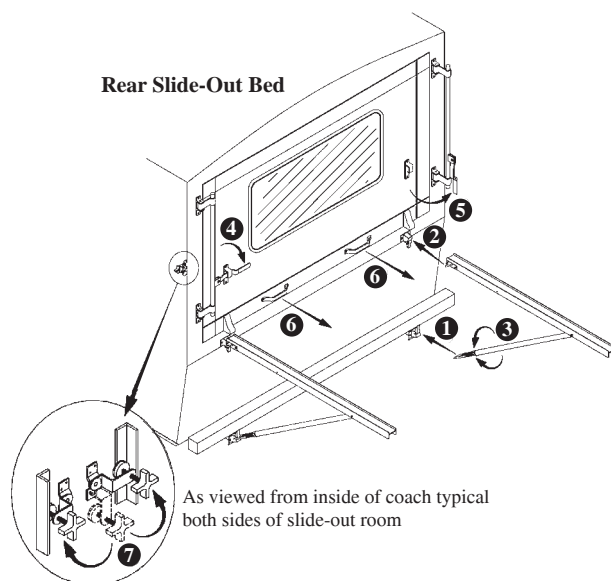

### Ramp Door Operation

If your recreational vehicle has been equipped with a rear entrance door/loading ramp, the following steps should be taken in operating the door to prevent injury or damage.

1. Select a parking site where the edge of the rear door/loading ramp will rest entirely on a flat, level surface.
2. Level the trailer according to the leveling section of this manual.
3. Unlock the rear door/loading ramp and carefully lower it to the ground.
4. Use caution while loading or unloading items from the cargo area so as not to damage the door seals.
5. Make certain that the door seals and the hinge area are cleared of any debris, such as sand or snow, before closing the rear door/loading ramp.
6. Before moving the trailer, make certain the rear door/loading ramp is closed and securely locked.
7. Inspect the hinges, assist springs, and latch mechanism before each trip for signs of wear or damage, and make any needed repairs for safe operation and towing.

## Chapter 9: Care and Maintenance

The instructions and recommendations located within this manual and the accompanying manufacturer's component literature should be read, as failure to perform necessary or preventative maintenance may limit or void all or part of a specific warranty.

Care and maintenance of the recreational vehicle is an important step in maintaining the safety, dependability and the appearance, both interior and exterior, of the unit. Keep good records of all maintenance performed as these may be necessary for warranty information or may assist in possible repairs needed.

Operational usage and climates may affect the frequency of maintenance needed on certain components. Preventative maintenance is important to the life and enjoyment of any recreational vehicle as many problems can be caught before they occur. Please do not hesitate to call your dealer with a question on the maintenance or care of any item.



Never exceed the capacity of the ramp door (see label on door). Exceeding the capacity can cause permanent deformation of door, inability to seal or complete failure.

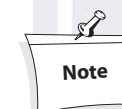

All stabilizer jacks must be used.



Rear door weighs approximately 200 pounds and is designed for two person operation.



The care and maintenance of appliances are discussed within the appliance chapter. Always refer to the manufacturer's recommendations located within the literature contained within the unit packet.

## Exterior

### Fiberglass/Gel Coat Finish

Care of the fiberglass finish is similar to caring for a new car. Any finish will deteriorate over time. Exposure to extreme sunlight, pollutants, and excessive moisture can cause dulling, fading and yellowing. Regular washing and periodic waxing will help maintain the glossy new look. When washing, use a mild, automotive or RV wash solution, available at your dealer, being sure to rinse off any loose debris first. Avoid spraying water directly into the furnace and refrigerator vents. Waxing the fiberglass areas twice a year is recommended. Wax with an automotive wax or polish developed for boats. Follow all directions by the wax manufacturer carefully and remember to wash and wax out of direct sunlight and when surfaces are cool.

### Metal

The aluminum exterior has a baked on enamel finish. Washing frequently with an automotive or RV wash solution will help avoid staining from debris and soil build up. Always rinse unit with clear water prior to washing to remove any loose dirt. Waxing two to three times a year with a good automotive paste wax will help preserve the finish.

### DO'S and DON'TS

- Do Use Automotive/Marine grade non-abrasive waxes.
- Do Use Soft cloths to clean and wax.
- Do be careful around graphics. Wax and wash with the graphic, not against it.
- DO NOT USE products containing ammonia or caustic harsh cleaners as they may cause discoloration to the fiberglass surface.
- Do Not use high-pressure washers, rotating brushes, such as in car washes, and power buffers. Use of these products can damage graphics and/or paint finishes.
- Do not dry wipe surfaces.
- Do not use rubbing compounds.

### ABS Plastic/Molded Parts

Some components of Skyline products are constructed of strong ABS molded plastic. A mild solution of soap and water should be used when cleaning. When using any product, make sure the product is recommended for use on plastics. Avoid harsh abrasive cleaners, ammonia or citric-based products as discoloration may result.

Carefully read the component manufacturer's manual for complete instructions and any applicable safety instructions, provided in the unit packet, prior to performing any maintenance.

### Roof

The roofing system is a EPDM rubber membrane that will not rust or corrode and is quieter than metal roof systems. The rubber roof material itself does not require annual coatings or additional sealants. Wrinkles may develop in the material due to expansion and contraction from heating and cooling but this does not affect the integrity of the roof and is not a cause for concern.

The roof material can, however, be cut by sharp objects. Care is needed when driving or parking to avoid punctures. If damage does occur, the roof may be patched with a special kit available through your dealer. If accessories or new equipment are added, be sure the installer is qualified to work on the rubber roof material.

### Maintenance

Inspect the roof at least every 90 days, paying particular attention to the seams where the areas of sheet metal, moldings, rubber and/or fiberglass are joined. Carefully inspect the sealant around any vents, skylights, air conditioners, etc.

Exposure to the elements will cause sealants to deteriorate over time. Variations in climate and weather may accelerate deterioration. Inspection and periodic resealing is essential as preventative maintenance. If cracks or shrinkage are noticed, immediately follow the rubber roof manufacturer's recommendations for repair or resealing. Special sealants are used due to the composition of the roofing material. For the appropriate sealant, please see your dealer.

### Cleaning

Prior to cleaning the roof, rinse off the roof to remove any debris. Be sure to keep the sidewalls wet to reduce streaking. Standard household detergents can be used for normal cleaning. Do not use petroleum

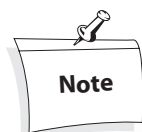

#### Note

Generally, only models factory equipped with an exterior ladder have a roof capable of walking on. Otherwise walking or storing materials on the roof is not recommended.



**THE RUBBER ROOFING MATERIAL, WHEN WET, MAY BE SLIPPERY. ALWAYS USE CAUTION WHEN WORKING ON TOP OF THE RV.**

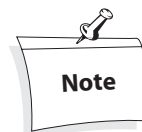

#### Note

Do not use acetone or any products containing petroleum distillates on the rubber roof.

solvents, harsh abrasives or citric-based cleaners that can damage the membrane. Appropriate cleaners such as Dicor Roof Cleaner™ are available through your dealer. Remember to rinse thoroughly after cleaning.

For more stubborn stains (i.e. oak leaves, pine sap) the use of a kitchen cleanser with bleach can help remove the stain. Remember to rinse the roof completely to remove any soap residue and also rinse the sidewalls completely to remove any streaking. After cleaning the roof check the membrane for possible damage and check the caulk/lap sealant at exhaust stacks, vents, and fasteners.

Substantial accumulation of snow should be removed from any roof especially on a trailer not occupied during the winter.

### **Seals and Adhesives**

The seals and adhesives used perform an important job, keeping out an RV enemy — water. Close inspection and routine maintenance are crucial to the longevity of the trailer. While many types are used, none have a pre-set lifetime, as exposure to the elements and regional variances of climate can accelerate any sealant's deterioration. Therefore, every six months, inspection of all seals is recommended and a quick inspection prior to every trip will help reduce potential problems down the road.

When inspecting, check for cracks, voids, shrinkage, or any sign of deterioration. If any of these signs are noticed, have your dealer inspect and replace the sealant if necessary. It is important to use the same kind of sealant that was previously used.

### **Access Doors**

Convenient access doors are provided for storage of items you do not wish to bring inside. All baggage doors have key locks for safe storage.

### **Doors, Windows, and Sliding Step**

**Door Catches** — The main entrance door is built of heavy gauge material and is fully insulated. The door lock design reflects the latest safety regulations. It is very important that the door be completely closed and locked during travel. If you find it is difficult to lock the door, push in to release pressure on the door latch while turning the key. The door is locked from the inside by pushing or turning a button near the door handle.

### **Windows (Exterior)**

As with seals, check the sealant around the windows at least once every six months. If any interior leaks are noticed, contact an authorized dealer immediately. To ensure window operation, adjust and lubricate latches and any moving parts annually. A light oil or powdered graphite can be used for lubrication. Periodically use a vacuum attachment to clean any debris out of the window weep holes, which are necessary to drain any condensation moisture or from hard driving rains that may collect.

Windows and window glass meet or exceed all federal safety standards. They require only normal care and may be cleaned with any good glass cleaner.

Window screens are made of plastic for longer wear and ease of maintenance. They can be easily cleaned with a mild cleaning solution. They will not rust and, in case of damage, can be replaced by your dealer.

### **Exterior Grill (Optional Some Models)**

The exterior grill is a propane-operated unit designed specifically for outdoor use. It must be mounted to the sidewall of the trailer using the bracket provided with the grill. See the manufacturer's manual for operating information. Allow grill to cool adequately prior to dismantling grill. Put in storage when not in use.

## **Frame and Chassis**

### **Frame and Bumper**

Over time, weather and climate such as rain, snow, salt, etc lead to corrosion. Rinse the undercarriage, wheel wells, hitch and bumper when needed to remove dirt, oil, tar, salt and other debris. Periodically inspect for rust. Near coastal regions, inspect more frequently. If needed, lightly sand and repaint with a rustproof enamel.

### **Steps**

Clean regularly to remove dirt, salt, mud, etc. and lubricate pivot points with a quality automotive grade lubricant every 30 - 60 days.



Seal any nicks or scratches with primer and then cover area with a quality high-gloss paint to prevent rusting. If rust is noticed, sand the area lightly and then cover with primer. Follow with high gloss paint. Be sure the step is fully retracted while in transit.

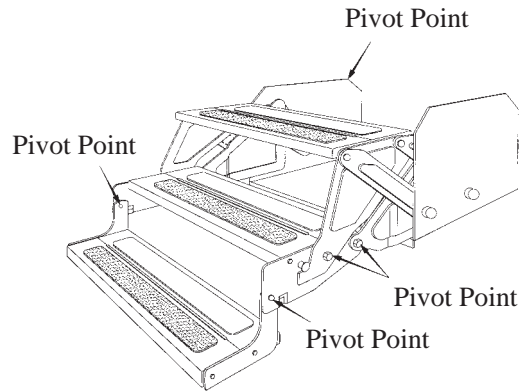

### Hitch Couplers

Inspect prior to each trip. The ball socket and clamp should be cleaned and lubricated monthly with wheel bearing grease. If coupler or coupler components appear damaged or worn, contact your dealer upon notice of the problem.

### Fifth Wheel Coupler

Inspect monthly or prior to each trip. The hitch plate and locking mechanism should be generously lubed at all times with a high temperature rated grease. Consult the paperwork that accompanied the hitch purchased for manufacturer recommendations.

### Safety Chains

Safety chains should be inspected monthly. If chains are damaged or weakened, replace immediately. Never tow without use of the safety chains.

Carefully read the component manufacturer's manual and any safety instructions, provided in the unit packet, prior to performing any maintenance.

### Jacks

- Tongue Jacks, Manual (travel trailers)

Whenever preparing to travel, inspect the jack for any damage and test operation. If jack is difficult to operate, clean and oil lightly. If jack is still difficult to operate or freezes, call your dealer. Service on any jack should be performed by qualified service personnel only.

- Tongue Jacks, Power (travel trailers)

Prior to traveling, inspect the jack for any damage and test operation. Check connections at battery and keep contacts clean and secure. If the power jack malfunctions at any time, call a local dealer. Service on all power jacks should be performed by trained service personnel.

- Fifth Wheel Jacks

Prior to each use inspect drop tube and inner ram tube. Replace or repair as required per component manufacturer instructions. Follow all preventative maintenance instructions provided on the specific component installed. If malfunction occurs, immediately call your local dealer. Service on any jack should be performed by qualified service personnel only.

Carefully read the component manufacturer's manual and any safety instructions, provided in the unit packet, prior to performing any maintenance.

## Tires and Wheels

The tires should be checked before starting out on any trip. Check them regularly and keep inflated to recommended pressures. The recommended tire pressure is on the side of the tire. A tire gauge is a very inexpensive and valuable tool for checking tire inflation. Rotate the tires at least once every 5,000 miles. You may want to have a spare tire with you in case of an emergency.

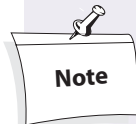

#### Note

If equalizer (weight distribution) bars are attached to vehicle while attempting to operate a power tongue jack, the motor may clutch and/or seize upon attempting to bear the load. Damage to the jack under these circumstances will not be covered by Skyline or the jack manufacturer.



SOME PROCEDURES REQUIRE THE USE OF SPECIAL TOOLS FOR SAFE AND CORRECT MAINTENANCE. DO NOT ATTEMPT TO SERVICE, REPAIR OR WORK ON ANY AXLE, BRAKE, OR WHEEL SYSTEM UNLESS YOU HAVE APPROPRIATE SKILLS AND KNOWLEDGE. LACK OF PROPER TRAINING, FAILURE TO FOLLOW PROCEDURES OR USE SPECIAL TOOLS AND SAFETY EQUIPMENT COULD RESULT IN PROPERTY DAMAGE, SERIOUS INJURY OR LOSS OF LIFE.

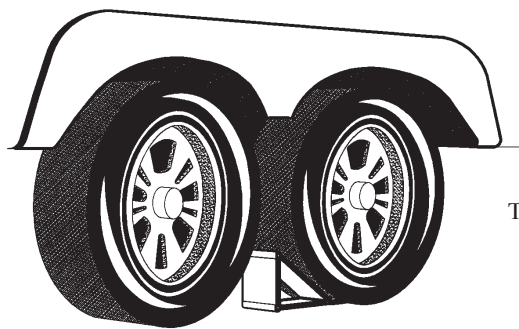

Typical Wheel Chocks

### Tire Changing Basics

1. Turn on the tow vehicle's hazard warning flashers.
2. Set up flares or warning lights.
3. Chock the opposite tire and unhitch the trailer from the tow vehicle, or reduce tension on equalizer bars, if applicable.
4. DO NOT use a bumper jack; it may damage the sidewalls or floorboard of the trailer.
5. Place scissors-type or hydraulic jack on a block of wood, directly UNDER THE MAIN CHASSIS RAIL, close to the tire you intend to change.

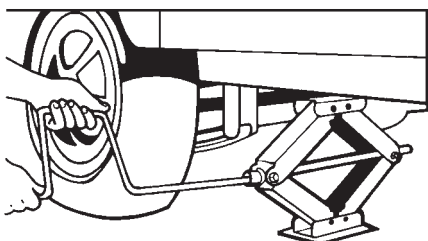

Typical Scissor Jack

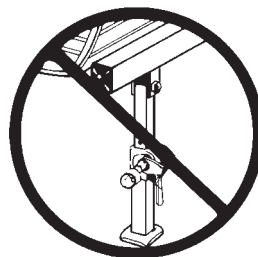

Never Use Bumper Jacks

6. Raise the jack to take some of the weight off the tire.
7. Loosen the lug nuts.
8. Raise the jack until the tire clears the ground.
9. Remove the lug nuts, pull off the old tire, and put the spare on the hub.
10. Replace and tighten the nuts.
11. Lower the jack until the tire just touches the ground.
12. Tighten the lug nuts as specified below - see wheel nut torque.
13. After torquing lug nuts, lower and remove the jack.
14. BE SURE TO STOP AT THE NEAREST SERVICE FACILITY AND HAVE THE TORQUE CHECKED.

### Wheel Nut Torque

The axle and wheel assemblies of your RV are designed differently than those on your car. The overall size, weight and center of gravity of a recreational vehicle subject the wheels to pressures unique to trailering. During normal cornering, the tires and wheels experience a considerable amount of stress called "side-load". Therefore, the lug nuts on your recreational vehicle require periodic retorquing.

These instructions will show you how to maintain proper lug nut torque by following these important steps:

### **!** WARNING

**WHEEL LUGS MUST BE PROPERLY TORQUED. TIGHTEN ALL LUG NUTS BEFORE FIRST MOVEMENT AND AT 10, 25, AND 50 MILES. CAUTION: UNDERTIGHTENING OR OVERTIGHTENING MAY CAUSE LOSS OR DAMAGE TO WHEELS, HUBS, OR BRAKING CAPABILITY, WHICH COULD RESULT IN SERIOUS PERSONAL INJURY OR DEATH. PLEASE REFER TO THE INSTRUCTION AND MAINTENANCE MANUAL FOR RUNNING GEAR.**

### Bolting Star Pattern

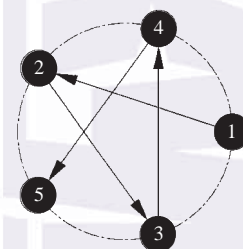

Five Lug Bolt Pattern

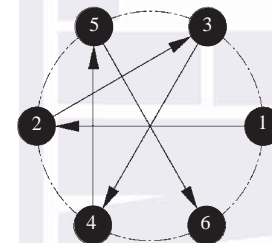

Six Lug Bolt Pattern

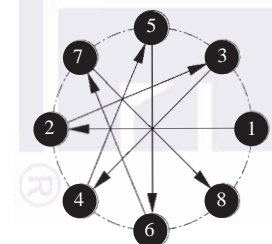

Eight Lug Bolt Pattern

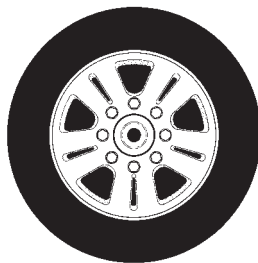

1. Check torque before every trip
2. Use proper tools
3. Follow the appropriate star pattern sequence (on page 57).
4. Torque lug nuts in the correct stages and follow-up intervals after any wheel reinstallation. See the following chart.

### STEEL WHEEL TORQUE REQUIREMENTS

Wheel Size	Torque Sequence		
	1st Stage (ft-lb)	2nd Stage (ft-lb)	3rd Stage (ft-lb)
14"	20-25	50-60	85
15"	20-25	50-60	120
16" - 6 Lug	20-25	50-60	120
16" - 8 Lug	20-25	50-60	130

### ALUMINUM WHEEL TORQUE REQUIREMENTS

Wheel Size	Torque Sequence		
	1st Stage (ft-lb)	2nd Stage (ft-lb)	3rd Stage (ft-lb)
16" - 6 or 8 Lug	30-35	70-80	180

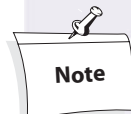

**Note**

Some wheel assemblies require an extension. **DO NOT USE** a flexible extension. Also, **DO NOT USE** a 4-way socket or any other type of wrench, which does not measure the actual pressure applied to the lug nut.

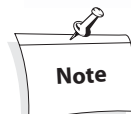

**Note**

If uncertain or unfamiliar with any procedure, please call your local dealer.

Remember, torque is the amount of rotating force applied to a fastener, such as a lug nut. Proper torque of lug nuts can only be achieved by using a torque wrench and a socket.

- Dial indicator or adjustable dial torque wrench
- 7/8" or 13/16" socket

**Using Torque Wrenches:**

- Most torque wrenches are required to be set at "0" when not in use to maintain calibration.
- Please refer to the manufacturer's instructions for further information on use and maintenance.

**Setting Torque Value on a Dial Indicator Wrench:**

1. Make sure your indicator needle is set to "0".
2. As you apply clockwise pressure to the lug nut, both needles will show the current amount of torque being applied.
3. When you reach your desired torque value, stop applying pressure and your indicator needle will stay at the highest torque value reached.

**Setting Torque Value of Adjustable Dial Wrench:**

1. Unlock the handle and set the dial to your desired torque value.
2. Lock the handle back in place.
3. As you apply clockwise pressure to the lug nut, you will hear an audible "click" when the desired torque wrench value is reached. Do not apply further pressure once you hear the "click".



### Always Remember:

- Check lug nut torque before every trip. Skyline recommends this maintenance procedure to ensure proper torque has been applied to lug nuts before heading out on the road.
- Lug nuts should be torqued according to the preceding chart. Each wheel should be re-torqued after the first 10, 25 and 50 miles after replacing a wheel or after a long period of storage to the final torque value for your wheels size and type.
- Always follow the appropriate star pattern as indicated on the previous page or in your axle manufacturer owner's manual to assure proper torque.

### Pre-Trip Procedure:

1. Set your torque wrench to the appropriate torque for your wheel size and type.
2. Begin with the appropriate bolt for your wheel (3 o'clock position) and apply torque to all lug nuts following the star pattern indicated.
3. Complete the procedure on each wheel. Before moving to each new wheel, be sure to verify your preset torque wrench value.

After removing a wheel from your RV for any reason, you must carefully follow a 2-step process:

1. Wheel Reinstallation
2. Follow-up

### Step 1) Wheel Reinstallation

During wheel reinstallation, the lug nut torque must be applied in 3 stages. This will ensure the wheel studs are centered in the wheel holes, and will help the lug nuts maintain proper torque. When following the steps below refer back to the torque requirements chart in the section "Wheel Nut Torque" to find the correct torque value for your wheel size and type.

1. Start all lug nuts by hand.
2. Stage 1: Set your torque wrench to the 1st stage torque value for your wheel size and type.
3. Begin with the appropriate bolt for your wheel (3 o'clock position) and apply torque to all lug nuts following the star pattern indicated on page 57.
4. Stage 2: Increase your torque wrench setting to the 2nd stage torque value for your wheel size and type.
5. Begin with the appropriate bolt for your wheel and apply torque to all lug nuts following the star pattern as in stage 1.
6. Following stage 2, the wheel can support the weight of the trailer and can be lowered off of the jack stands.
7. Stage 3: Increase your torque wrench setting to the 3rd stage torque valve for your wheel size and type.
8. Begin with the appropriate bolt for your wheel (as illustrated) and apply torque to all lug nuts following the star pattern indicated on page 57.

### Step 2) Follow-Up: Retorque after 10, 25 and 50 miles:

1. After the first 10 miles of your trip, pull your recreational vehicle off the road into a safe work area.
2. Set your torque wrench to the 3rd stage torque valve for your wheel size and type.
3. Begin with the appropriate bolt for your wheel and apply torque to all lug nuts following the star pattern indicated in the wheel nut torque section of this manual.
4. Reapply torque and repeat steps 1, 2 and 3 again at 25 miles and at 50 miles of your first trip.
5. The follow up process is complete.

### Summary

1. Check torque before every trip
2. Use proper tools
3. Follow the appropriate star pattern sequence
4. Torque lug nuts in the correct stages and follow-up intervals after any wheel reinstallation

### Wheel Bearing Lubrication

Wheel bearings should be repacked every 6000 miles or every 6 months. Every time the wheel hub is removed, the wheel bearings must be adjusted. Turn the hub slowly to seat the bearings while tightening the spindle nut until the hub will no longer turn. Loosen the spindle nut so it may be turned by hand. Tighten nut finger tight then loosen to first hub slot allowing alignment. Install cotter pin.

The spindle nut and hub should be free to move with the cotter pin being the only restraint.

Prepare bearings by cleaning with solvent to remove the old grease. Repack by pressing fresh bearing grease into bearing roller area. Repack bearings more often if subject to extremely wet conditions. If trailer has not been used for more than 2 months, the wheel bearings should be inspected and repacked if necessary.



WHEEL SEPARATION CAN OCCUR.

ON THE FIRST TRIP, CHECK FOR THE PROPER TORQUE EVERY 10, 25 AND 50 MILES TRAVELED. THIS PROCEDURE SHOULD ALSO BE REPEATED EVERY TIME A WHEEL IS REPLACED.



ALWAYS TORQUE WHEEL NUTS TO THE WHEEL MANUFACTURER'S SPECIFICATIONS. OVER OR UNDERTORQUED WHEEL NUTS CAN CAUSE THE WHEEL TO SEPARATE FROM THE WHEEL MOUNTING SURFACE DURING OPERATION, CAUSING PROPERTY DAMAGE, PERSONAL INJURY OR LOSS OF LIFE.



DO NOT TOW THE TRAILER WITH MISSING LUG NUTS OR FAULTY LUG BOLTS.



INSTALLATION OF WHEELS WHICH ARE NOT COMPATIBLE WITH THE MANUFACTURER INSTALLED AXLE ASSEMBLY COULD RESULT IN WHEEL SEPARATION, WHICH CAN LEAD TO PROPERTY DAMAGE, SERIOUS INJURIES OR LOSS OF LIFE.



SOME PROCEDURES REQUIRE THE USE OF SPECIAL TOOLS FOR SAFE AND CORRECT MAINTENANCE. DO NOT ATTEMPT TO SERVICE, REPAIR OR WORK ON ANY AXLE, BRAKE, OR WHEEL SYSTEM UNLESS YOU HAVE APPROPRIATE SKILLS AND KNOWLEDGE. LACK OF PROPER TRAINING, FAILURE TO FOLLOW PROCEDURES OR USE SPECIAL TOOLS AND SAFETY EQUIPMENT COULD RESULT IN PROPERTY DAMAGE, SERIOUS INJURY OR LOSS OF LIFE.

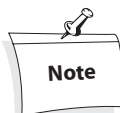

**Note**

When storing a battery, do not place the battery directly on concrete, as the battery will discharge more rapidly.

**WARNING**

THE ACID IN BATTERIES IS HIGHLY CORROSIVE AND HYDROGEN GAS IS PRODUCED WHICH IS EXTREMELY FLAMMABLE. AVOID PLACING NEAR A POSSIBLE IGNITION SOURCE SUCH AS OPEN FLAME OR POTENTIAL SPARK PRODUCING WIRING.

**WARNING**

BEFORE PERFORMING ANY MAINTENANCE ON THE BATTERY, ALWAYS DISCONNECT THE BATTERY, REMOVING THE NEGATIVE (-) CABLE FIRST AND THEN DISCONNECTING THE POSITIVE (+).

**WARNING**

ALWAYS DISCONNECT THE NEGATIVE (-) CABLE PRIOR TO WORKING NEAR BATTERIES TO REDUCE RISK OF ARCHING AND IGNITING.

Repack bearing using a high temperature, automotive type wheel bearing grease produced by a reputable manufacturer.

Carefully read the component manufacturer's manual and any safety instructions provided in the unit packet prior to performing any maintenance.

**EZ Lube/Super Lube**

If the recreational vehicle is equipped with EZ Lube or Superlube, there is no need to remove hubs to grease axle bearings. To grease follow these simple steps:

1. Remove the rubber plug from the grease cap
2. Insert grease gun on the grease zerk
3. Pump until new grease begins to appear
4. Replace rubber plug

Hubs and components still need to be inspected and maintained per the manufacturer's guidelines.

Carefully read the component manufacturer's manual and any safety instructions provided in the unit packet prior to performing any maintenance.

**Brake Adjustment**

The electric brakes are of the drum and two-shoe type and adjust the same as most automotive brakes. Adjust brakes after the first 200 miles. Every 3 months or 3000 miles, test the brake drag and adjust if required. Full procedures are outlined in the component manufacturer's guide, included in the unit packet. Never adjust just one brake. When adjusting brakes on any vehicle, either replace or adjust all brakes at the same time, or at least both brakes on the same axle.

**Battery (Not Supplied by Skyline)**

Before performing any maintenance on the battery, always disconnect the battery cables from the battery. To inspect the electrolyte level, remove the vent covers and visually ascertain the electrolyte level in each cell. Using a small flashlight may help. (If a maintenance free battery has been purchased — no way exists to check these levels.) If the level needs to be replenished in any or all cells, carefully pour in distilled water only. Never use acid or tap water. Tap water contains minerals and chemical impurities that will permanently damage the battery. Besides maintaining the electrolyte level, visually inspect the battery for loose terminals, corrosion, or any damage to the vent covers or case. Tighten any loose clamps on the terminals of the battery and clean any corrosion off the terminals. An inexpensive device for cleaning these terminals can be purchased at automotive stores.

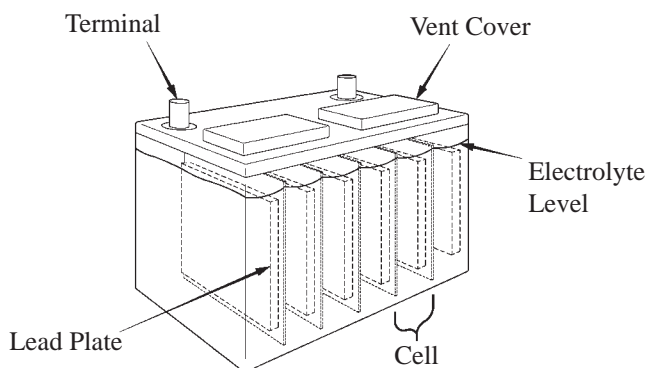

When working with batteries, be extremely careful. The acid in batteries is highly corrosive and flammable. Batteries produce a flammable hydrogen gas that will explode if ignited. Never place batteries in any compartment or near anything that could spark, even a 12 Volt switch. Never smoke or use open flames anywhere near the battery. Never inhale fumes from battery cells. Secure batteries in a battery box or in a compartment specially designed for battery storage. Wear safety glasses and appropriate clothing when performing any maintenance on a battery. In case of a spill or splash, immediately flush the affected area with cold water for 15 minutes and call the poison control center for further instructions.

**Battery Storage**

When storing the RV for an extended period, fully charge the battery before storage. Batteries will self-discharge over time and are subject to freezing, especially if in a discharged condition. Inspect batteries while in storage every 2 to 3 weeks. Hook up a battery charger at least once a month to prevent discharge and sulfation. An easy solution is to remove the battery completely from the unit during storage and place it at home in a warmer location, such as a garage, so that the battery condition can be monitored and charged as needed during storage periods.

**Appliances: See Chapter 4****Bedspreads**

In most instances or whenever in doubt, dry clean all fabric products such as drapes and bedspreads for best appearance and prolonged life. Washing draperies and bedspreads in washers will cause premature deterioration, fading, shrinkage and/or possible damage.

**Blinds and Shades**

Venetian blinds and day/night shades should be vacuumed regularly with a soft brush attachment. Use of a soft cloth and mild cleaner on blinds will help keep them new looking. For fabric shades, upholstery cleaners are not recommended. Instead, spot clean when necessary, using a mild soap and water solution on area.

**Cabinet Doors and Drawers (Wood)**

The cabinet doors and drawer fronts should be cared for similar to the fine furniture in your home. Using a quality furniture polish will help maintain the beauty and luster of the wood as well as keep the wood from drying out. The accidental scratches can be covered satisfactory with a good quality commercial furniture scratch remover.

**Carpeting**

The carpeting installed is made of synthetic fiber and is easy to maintain. Vacuum regularly to remove abrasive grit. Water based spills and spots should be removed immediately with a damp cloth. Grease or oil based stains and spots should be spot cleaned with a good commercial spot cleaner made for this purpose. If complete shampooing is desired, it is best to have it done by a competent professional carpet cleaner. Never soak or water-log your carpeting.

**Ceilings and Walls**

Clean only with a mild detergent in warm water, using a damp cloth to clean the ceiling. Never use strong chemicals or excessive water/moisture, as either can damage the ceiling or walls.

**Countertops**

Most countertops are made of high-pressure plastic laminates and are highly resistant to normal spills and scuffs. Soap and lukewarm water or a mild, non-abrasive cleaner are recommended. Avoid use of abrasive pads and scouring powders, which can dull the surface and make it more stain-prone. Always use a chopping block or cutting board when using knives. Pots and pans straight from the burner or oven should be placed on lined hot pads and not directly on the counter surface.

**Draperies**

Draperies and upholstery fabrics should always be dry cleaned like any other fine fabric by a competent dry cleaning establishment. Spots and stains should be removed with a non-water based commercial spot remover manufactured for this purpose.

**Faucets and Fixtures**

To protect the finishes on your kitchen and bath faucets and fixtures, use only a damp soft cloth or sponge. Do not use abrasive cleaners or materials as they can damage the finish.

**Flooring, Vinyl**

For routine cleaning, sweep or vacuum regularly. Follow by using a damp mop with warm water and clean a small area at a time. Rinse the mop frequently as to not redistribute the picked up dirt. If washing is needed, use a quality product designed for no-wax flooring. To polish the floor, do not use solvent-based waxes or polishes as damage to the flooring may result. Use only polishes recommended for no-wax flooring.

**Glass and Mirrors**

Clean glass and mirrors as you would at home using a cleaner designed for glass. To reduce "spotting" on outside windows, use a squeegee promptly after rinsing with water. For stubborn spots, cleaning with a mixture of vinegar and water is recommended and is safe for most finishes.

**Fabric and Upholstery**

Do not launder upholstery fabrics. Blot up stains promptly and use an upholstery cleaner or mild solvent, depending on the stain. Never soak the fabric and use as little water as possible. Blot rather than rub. Towel dry or have professionally cleaned. Upholstery can be vacuumed regularly using a soft brush attachment.

**Sinks, Tubs and Toilets**

Many of these products are made of acrylics, plastics or composite materials and use of non-abrasive cleaners is recommended to protect the finish. Use of harsh cleaning products can cause premature deterioration and/or yellowing of the surface finish.



Avoid use of kerosene, naphtha, carbon tetrachloride, lighter fluid, or abrasive cleaners or commercial cleaners containing them. They will harm the finish on unprotected surfaces, and may cause malfunctioning of carbon monoxide and propane detectors.

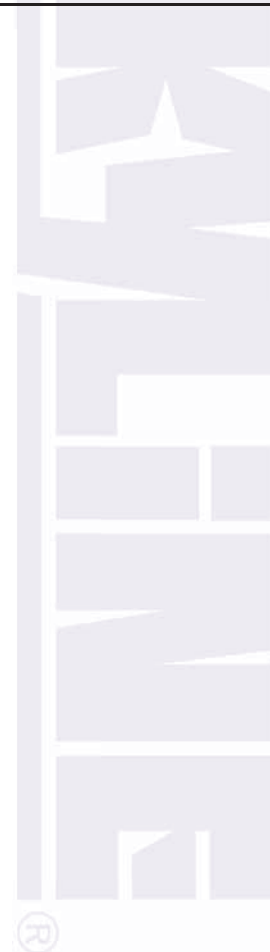

### Interior Tables and Beds

A variety of tables and sofas, some of which can be made into sleeping accommodations, are installed in Skyline travel trailers and fifth wheel vehicles. Some of these are stored in enclosures at the side-walls (exterior type), while others are a part of a dinette arrangement. The following explanations and illustrations explain the operation of these accommodations.

**FOLDING TABLE LEG** — To operate this type of table leg, pull the leg down. If the table has an extension leg, push the release and allow the inner leg to drop to the length necessary to make the top level. Let the lock pin seat in the hole to hold the leg at the proper length.

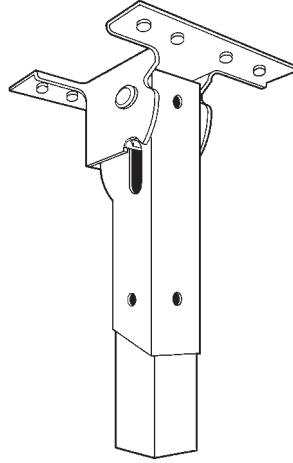

Typical Table Latch

**SWING-DOWN TABLE** — Pull the table towards you and up, then push it toward the wall. Insert the brackets (tabs) at the back of the table into the wall support brackets. Pull the leg down into place.

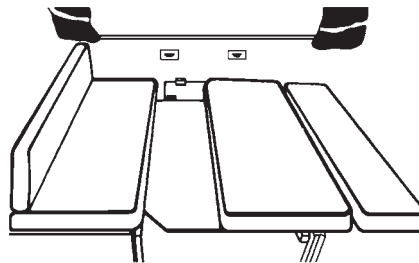

Swing-Down Table

**PEDESTAL TYPE** — Drop the table top to the level of seats. Place seat back cushions over table top to form bed.

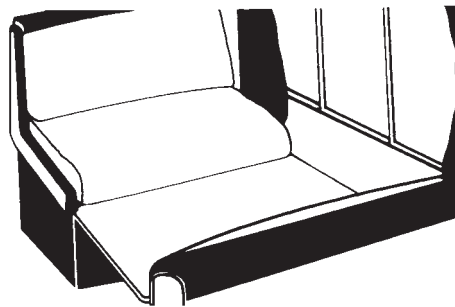

Pedestal Table

**PEDESTAL TYPE** — Simply insert the table leg (or legs) into the base plate or plates. Lower the table support bracket into the legs.

**GAUCHO BEDS** — Lift the front edge of the lounge platform and slide it forward. Arrange cushions on the platform to serve as a mattress.

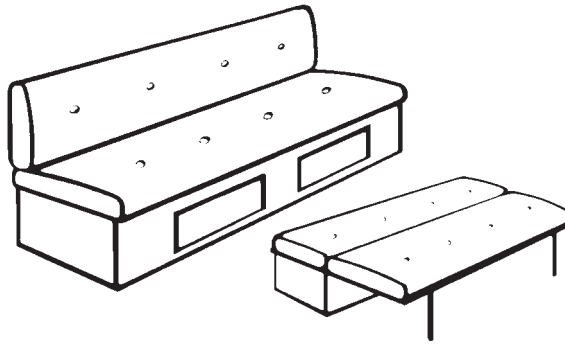

Gaucho Beds

**CABINET BUNK** — Open the cabinet doors at each end of the cabinet and release the latches on the inside of the cabinet facing. After releasing the latches, close the cabinet doors and drop the cabinet facing to a position level with the cabinet bottom. Secure the doors in the closed position with the hook & eye fasteners to prevent doors from opening unexpectedly, causing injury to someone below the bunk. (The facing should rest on the supports provided.) Place the reinforcing boards on top of the cabinet face and arrange the mattress sections to complete a bed.

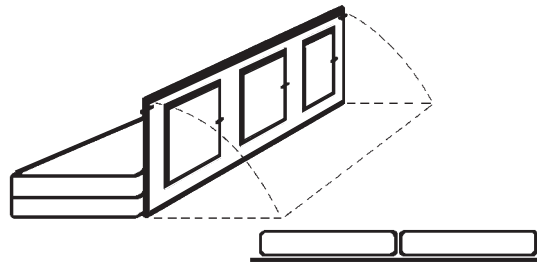

Cabinet Bunk

**ROLLOVER SOFA** — Pull the back of the sofa forward until the back rolls over to form the front half of the bed.

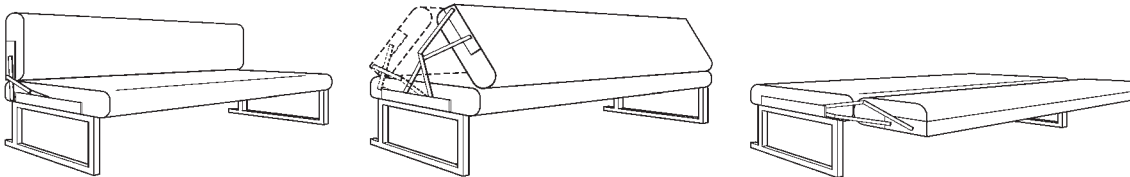

Rollover Sofa

**HIDE-A-BED SOFA** — To adapt these into a bed, remove the seat cushions, lift the mechanism, and pull forward. The mattress, which is folded and stored under the cushions, will unfold to form a bed.

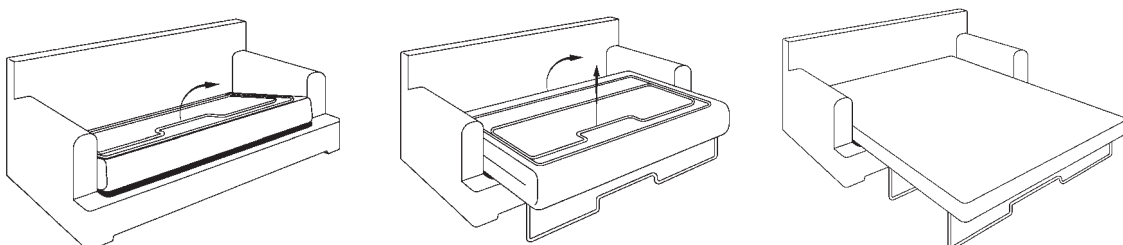

Hide-A-Bed Sofa





**JACKKNIFE SOFA** — Lift the front edge of the sofa seat and pull forward. The seat will lift and move forward as the back of the sofa drops to make into a bed.

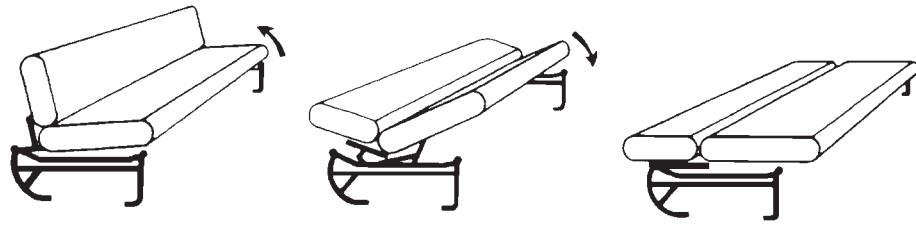

Jackknife Sofa

## Storage

If you plan to store your recreational vehicle for a prolonged period of time you should perform the following procedures to protect and maintain your vehicle.

### Propane System

Close the propane container's service valve. Extinguish all pilots and close all appliance propane valves (oven/range, water heater, refrigerator, furnace). Light a range burner (or range pilot on eye-level models) to consume any gas remaining in the lines. When the flame burns out, turn the range burner (or pilot) OFF.

### Plumbing System

Follow procedures for winterization in plumbing chapter.

### Smoke Detector

Remove batteries.

### Electrical System

Turn off all circuit breakers at the service panel. If the trailer is equipped with a generator, turn off the generator at the switch in the generator compartment.

### Exterior

Place the unit in a garage or other shelter. If this is not possible, cover it with a tarpaulin or plastic.

### Interior

Close and secure all doors and windows. Open a roof vent or window slightly to allow circulation, but not so far that rain or snow can enter. When storing the trailer, it is a good idea to protect the upholstery and interior from fading due to sunlight by putting aluminum foil between the window and the drapes.

### Refrigerator

Remove any food, etc. and block door open slightly. This will prevent odor and reduce chance for mildew or mold to develop. It is a good idea to leave a small open box of baking soda inside refrigerator while in storage.

## Maintenance Requirements

Maintenance intervals, checks, and inspections as prescribed in this manual are necessary to keep your vehicle in good working condition. Any damage caused by failure to follow recommended maintenance may not be covered by warranty.

### Recommended Maintenance Schedule

Service To Be Performed	Service Interval				
	Each Trip or Weekly	1,000 Miles 30 Days	3,000 Miles 90 Days	6,000 Miles Six Months	12,000 Miles Yearly
Pack Wheel Bearings				☆	
Inspect Brakes			☆		
Inspect Safety Chains	☆				
Inspect Brake Wiring	☆				
Inspect Tires	☆				
Inspect Hitch Components		☆			
Lubricate Locks					☆
Lubricate Coupler Latch & Socket	☆				
Lubricate Hinges					☆
Inspect + Clean Vents					☆
Torque Lug Nuts	☆				
Sanitize Water Tanks (if trailer has been stored)			☆		
Clean Drapes + Interior Fabrics				☆	
Clean Battery Cables & Terminals / Check Fluid	☆				
Inspect Suspension					☆
Check All Seams + Openings Reseal as Needed		☆			
Check Water System Components					☆





## Chapter 10: Tire Safety Information

This portion of the Owner's Manual contains tire safety information as required by 49 CFR 575.6.

Section 1, based in part on the National Highway Traffic Safety Administration's Brochure entitled "Tire Safety-Everything Rides On It," contains the following items:

Tire labeling, including a description and explanation of each marking on the tires, and information about the DOT Tire Identification Number (TIN).

Recommended tire inflation pressure, including a description and explanation of:

1. Cold inflation pressure
2. Vehicle Placard and location on the vehicle
3. Adverse safety consequences of underinflation (including tire failure)
4. Measuring and adjusting air pressure for proper inflation

Tire Care, including maintenance and safety practices. Vehicle load limits, including a description and explanation of the following items:

1. Locating and understanding the load limit information, total load capacity, and cargo capacity.
2. Calculating total and cargo capacities with varying seating configurations including quantitative examples showing/illustrating how the vehicle's cargo and luggage capacity decrease as combined number and size of occupants increases. This item is also discussed in Section 3.
3. Determining compatibility of tire and vehicle load capabilities.
4. Adverse safety consequences of overloading on handling and stopping.

Section 2 contains "Steps for Determining Correct Load Limit"

Section 3 contains a Glossary of Tire Terminology, including "cold inflation pressure", "maximum inflation pressure", "recommended inflation pressure" and other non-technical terms.

### Section 1

The National Highway Traffic Safety Administration (NHTSA) has published a brochure (DOT HS 809 361) that discusses all aspects of Tire Safety, as required by CFR 575.6. This brochure is reproduced in part below. It can be obtained and downloaded from NHTSA, free of charge, from the following web site:

[http://www.NHTSA.dot.gov/cars/rules/TireSafety/ridesonit/tires\\_index.html](http://www.NHTSA.dot.gov/cars/rules/TireSafety/ridesonit/tires_index.html)

Studies of tire safety show that maintaining proper tire pressure, observing tire and vehicle load limits (not carrying more weight in your vehicle than your tires or vehicle can safely handle), avoiding road hazards, and inspecting tires for cuts, slashes, and other irregularities are the most important things you can do to avoid tire failure, such as tread separation or blowout and flat tires.

These actions, along with other care and maintenance activities, can also:

- Improve vehicle handling
- Help protect you and others from avoidable breakdowns and accidents
- Improve fuel economy
- Increase the life of your tires.

The following presents a comprehensive overview of tire safety, including information on the following topics:

- Basic tire maintenance
- Uniform Tire Quality Grading System
- Fundamental characteristics of tires
- Tire safety tips.



Use this information to make tire safety a regular part of your vehicle maintenance routine. Recognize that the time you spend is minimal compared with the inconvenience and safety consequences of a flat tire or other tire failure.

### **Safety First — Basic Tire Maintenance**

Properly maintained tires improve the steering, stopping, traction, and load-carrying capability of your vehicle. Underinflated tires and overloaded vehicles are a major cause of tire failure. Therefore, as mentioned above, to avoid flat tires and other types of tire failure, you should maintain proper tire pressure, observe tire and vehicle load limits, avoid road hazards, and regularly inspect your tires.

### **Finding Your Vehicle's Recommended Tire Pressure and Load Limits.**

Tire information placards and vehicle certification labels contain information on tires and load limits. These labels indicate the vehicle manufacturer's information including:

- Recommended tire size
- Recommended tire inflation pressure
- Vehicle capacity weight (VCW-the maximum occupant and cargo weight a vehicle is designed to carry)
- Front and rear gross axle weight ratings (GAWR-the maximum weight the axle systems are designed to carry).

Both placards and certification labels are permanently attached to the trailer on the forward half of the left side, and are easily readable from outside the vehicle without moving any part of the vehicle.

### **Understanding Tire Pressure and Load Limits**

Tire inflation pressure is the level of air in the tire that provides it with load-carrying capacity and affects the overall performance of the vehicle. The tire inflation pressure is a number that indicates the amount of air pressure - measured in pounds per square inch (psi) - a tire requires to be properly inflated. (You will also find this number on the vehicle information placard expressed in kilopascals (kPa), which is the metric measure used internationally.)

Vehicle manufacturers determine this number based on the vehicle's design load limit. That is, the greatest amount of weight a vehicle can safely carry and the vehicle's tire size. The proper tire pressure for your vehicle is referred to as the "recommended cold inflation pressure." (As you will read below, it is difficult to obtain the recommended tire pressure if your tires are not cold.)

Because tires are designed to be used on more than one type of vehicle, tire manufacturers list the "maximum permissible inflation pressure" on the tire sidewall. This number is the greatest amount of air pressure that should ever be put in the tire under normal driving conditions.

### **Checking Tire Pressure**

It is important to check your vehicle's tire pressure at least once a month for the following reasons:

- Most tires may naturally lose air over time
- Tires can lose air suddenly if you drive over a pothole or other object or if you strike the curb when parking
- With radial tires, it is usually not possible to determine underinflation by visual inspection

For convenience, purchase a tire pressure gauge to keep in your vehicle. Gauges can be purchased at tire dealerships, auto supply stores, and other retail outlets.

The recommended tire inflation pressure that vehicle manufacturers provide reflects the proper psi when a tire is cold. The term cold does not relate to the outside temperature. Rather, a cold tire is one that has not been driven on for at least three hours. When you drive, your tires get warmer, causing the air pressure within them to increase. Therefore, to get an accurate tire pressure reading, you must measure tire pressure when the tires are cold or compensate for the extra pressure in warm tires.

### **Steps for Maintaining Proper Tire Pressure**

- Step 1. Locate the recommended tire pressure on the vehicle's tire information placard or certification label.
- Step 2. Record the tire pressure of all tires.
- Step 3. If the tire pressure is too high in any of the tires, slowly release air by gently pressing on the tire valve stem with the edge of your tire gauge until you get to the correct pressure.



Step 4. If the tire pressure is too low, note the difference between the measured tire pressure and the correct tire pressure. These “missing” pounds of pressure are what you will need to add.

Step 5. At a service station, add the missing pounds of air pressure to each tire that is underinflated.

Step 6. Check all the tires to make sure they have the same air pressure.



If you have been driving your vehicle and think that a tire is underinflated, fill it to the recommended cold inflation pressure indicated on your vehicle’s tire information placard or certification label. While your tire may still be slightly underinflated due to the extra pounds of pressure in the warm tire, it is safer to drive with air pressure that is slightly lower than the vehicle manufacturer’s recommended cold inflation pressure than to drive with a significantly underinflated tire. Since this is a temporary fix, don’t forget to recheck and adjust the tire’s pressure when you can obtain a cold reading.

### Tire Size

To maintain tire safety, purchase new tires that are the same size as the vehicle’s original tires or another size recommended by the manufacturer. Look at the tire information placard, the owner’s manual, or the sidewall of the tire you are replacing to find this information. If you have any doubt about the correct size to choose, consult with the tire dealer.

### Tire Tread

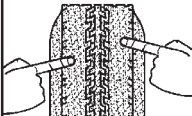
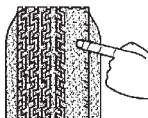
The tire tread provides the gripping action and traction that prevent your vehicle from slipping or sliding, especially when the road is wet or icy. In general, tires are not safe and should be replaced when the tread is worn down to 1/16 of an inch. Tires have built-in tread-wear indicators that let you know when it is time to replace your tires. These indicators are raised sections spaced intermittently in the bottom of the tread grooves. When they appear “even” with the outside of the tread, it is time to replace your tires. Another method for checking tread depth is to place a penny in the tread with Lincoln’s head upside down and facing you. If you can see the top of Lincoln’s head, you are ready for new tires.

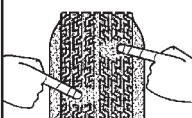
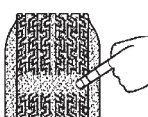
	Condition	Possible Cause	Remedy
	Even Center Wear	Over-Inflated Tire	Check & Adjust Pressure When Cold
	Inside & Outside Wear	Under-Inflated Tire	Check & Adjust Pressure When Cold
	Smooth Outside Wear (one side)	Loss of Camber or Overloading	Check & Unload as Necessary and/or Have Alignment Checked
	“Feathering” Across the Face	Axle Not Square to Frame or Incorrect Toe-In	Square Axle and/or Have Alignment Checked
	Cupping	Loose Bearings or Wheel Out of Balance	Check Bearing Adjustment and Wheel & Tire Balance
	Flat Spots	Wheel Lock-Up	Adjust Brakes



## Tire Balance and Wheel Alignment

To avoid vibration or shaking of the vehicle when a tire rotates, the tire must be properly balanced. This balance is achieved by positioning weights on the wheel to counterbalance heavy spots on the wheel-and-tire assembly. A wheel alignment adjusts the angles of the wheels so that they are positioned correctly relative to the vehicle's frame. This adjustment maximizes the life of your tires. These adjustments require special equipment and should be performed by a qualified technician.

## Tire Repair

The proper repair of a punctured tire requires a plug for the hole and a patch for the area inside the tire that surrounds the puncture hole. Punctures through the tread can be repaired if they are not too large, but punctures to the sidewall should not be repaired. Tires must be removed from the rim to be properly inspected before being plugged and patched.

## Tire Fundamentals

Federal law requires tire manufacturers to place standardized information on the sidewall of all tires. This information identifies and describes the fundamental characteristics of the tire and also provides a tire identification number for safety standard certification and in case of a recall.

## Information on Passenger Vehicle Tires

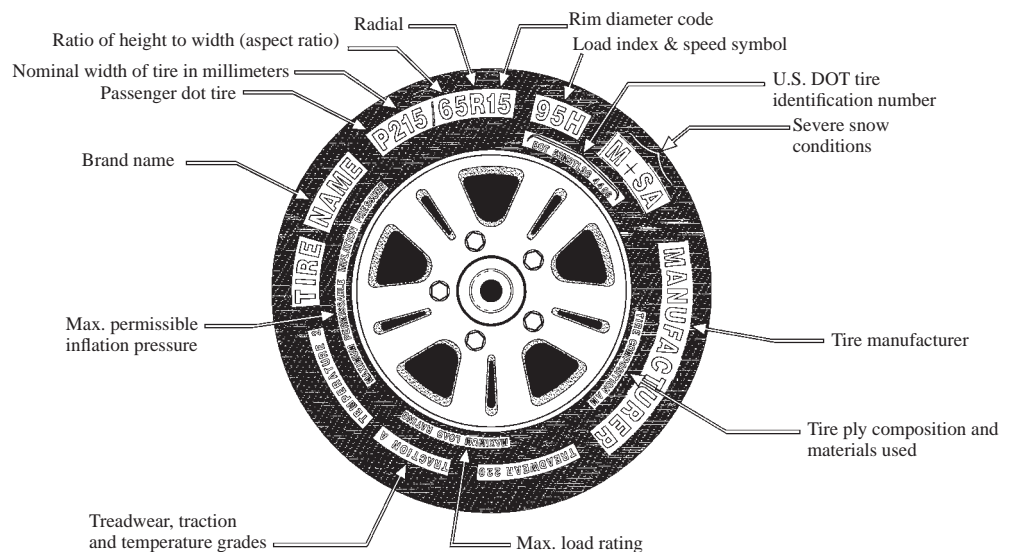

**P** - The "P" indicates the tire is for passenger vehicles.

**NOTE:** Passenger car tires are not recommended for use on trailers, because the capacity ratings marked on the sidewalls of these tires do not apply for travel trailers or fifth wheels. In the event a passenger car tire is used, the capacity must be derated by 10%.

**Next number** - This three digit number gives the width in millimeters of the tire from sidewall edge to sidewall edge. In general, the larger the number, the wider the tire.

**Next number** - This two-digit number, known as the aspect ratio, gives the tire's ratio of height to width. Numbers of 70 or lower indicate a short sidewall for improved steering response and better overall handling on dry pavement.

**R** - The "R" stands for radial. Radial ply construction of tires has been the industry standard for the past 20 years.

**Next number** - This two-digit number is the wheel or rim diameter in inches. If you change your wheel size, you will have to purchase new tires to match the new wheel diameter.

**Next number** - This two- or three-digit number is the tire's load index. It is a measurement of how much weight each tire can support. Note: You may not find this information on all tires because it is not required by law.

**M+S** - The "M+S" or "M/S" indicates that the tire has some mud and snow capability. Most radial tires have these markings.

**Speed Rating** - The speed rating denotes the speed at which a tire is designed to be driven for extended periods of time. The ratings range from 99 miles per hour (mph) to 186 mph. These ratings are listed below.

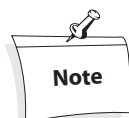

### Note

You may not find this information on all tires because it is not required by law.

Letter	Speed Rating
Q	99 mph
R	106 mph
S	112 mph
T	118 mph
U	124 mph
H	130 mph
V	149 mph
W	168* mph
Y	186* mph

\*For tires with a maximum speed capability over 149 mph, tire manufacturers sometimes use the letters ZR. For those with a maximum speed capability over 186 mph, tire manufacturers always use the letters ZR.

**U.S. DOT Tire Identification Number** - This begins with the letters "DOT" and indicates that the tire meets all federal standards. The next two numbers or letters are the plant code where it was manufactured, and the last four numbers represent the week and year the tire was built. For example, the numbers 3197 means the 31st week of 1997. The other numbers are marketing codes used at the manufacturer's discretion. This information is used to contact consumers if a tire defect requires a recall.

**Tire Ply Composition and Materials Used** - The number of plies indicates the number of layers of rubber-coated fabric in the tire. In general, the greater the number of plies, the more weight a tire can support. Tire manufacturers also must indicate the materials in the tire, which include steel, nylon, polyester, and others.

**Maximum Load Rating** - This number indicates the maximum load in kilograms and pounds that can be carried by the tire.

**Maximum Permissible Inflation Pressure** - This number is the greatest amount of air pressure that should ever be put in the tire under normal driving conditions.

### Additional Information on Light Truck Tires

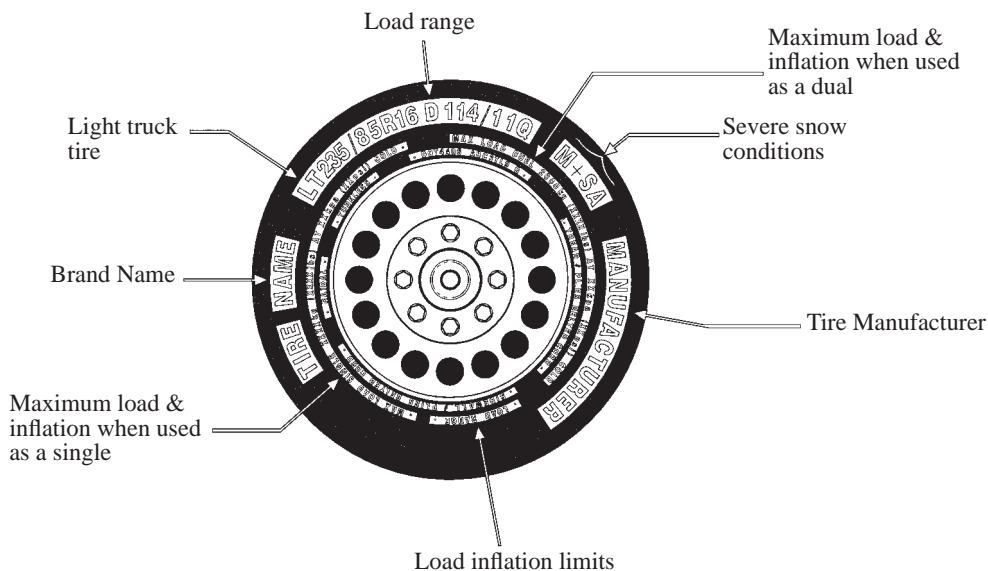

### Tires

Tires for light trucks have other markings besides those found on the sidewalls of passenger tires.

**LT** - the "LT" indicates the tire is for light trucks or trailers.

**ST** - An "ST" is an indication the tire is for trailer use only.



**Max. Load Dual kg (lbs) at kPa (psi) Cold** - This information indicates the maximum load and tire pressure when the tire is used as a dual; that is, when four tires are put on each rear axle (a total of six or more tires on the vehicle).

**Max. Load Single kg (lbs) at kPa (psi) Cold** - This information indicates the maximum load and tire pressure when the tire is used as a single.

**Load Range** - This information identifies the tire's load-carrying capabilities and its inflation limits.

**Vehicle Load Limits**

Determining the load limits of a trailer includes more than understanding the load limits of the tires alone. On all trailers there is a Federal certification/VIN label that is located on the forward half of the left (road) side of the unit. This certification/VIN label will indicate the trailer's Gross Vehicle Weight Rating (GVWR). This is the most weight the fully loaded trailer can weigh. It will also provide the Gross Axle Weight Rating (GAWR). This is the most a particular axle can weigh. If there are multiple axles, the GAWR of each axle will be provided.

If your trailer has a GVWR of 10,000 pounds or less, there is a vehicle placard located in the same location as the certification label described above. This placard provides tire and loading information. In addition, this placard will show a statement regarding maximum cargo capacity.

**Cargo Capacities**

Cargo can be added to the vehicle, up to the maximum weight specified on the placard. The combined weight of the cargo is provided as a single number. In any case, remember: the total weight of a fully loaded vehicle cannot exceed the stated GVWR.

Water and propane also need to be considered. The weight of fully filled propane containers is considered part of the weight of the RV before it is loaded with cargo and is not considered part of the disposable cargo load. Water, however, is a cargo weight and is treated as such. If there is a fresh water storage tank of 100 gallons, this tank when filled would weigh about 800 pounds. If more cargo is being transported, water can be off-loaded to keep the total amount of cargo added to the vehicle within the limits of the GVWR so as not to overload the vehicle. Understanding this flexibility will allow you, the owner, to make choices that fit your travel and camping needs.

When loading your cargo, be sure it is distributed evenly to prevent overloading front to back and side to side. Heavy items should be placed low and as close to the axle position as reasonable. Too many items on one side may overload a tire. The best way to know the actual weight of the vehicle is to weigh it at a public scale. Talk to your RV dealer to discuss the weighing methods needed to capture the various weights related to the RV. This would include weights for the following: axles, wheels, hitch or pin (in the case of a trailer) and total weight.

**How Overloading Affects Your RV and Tires**

The results of overloading can have serious consequences for passenger safety. Too much weight on your vehicle's suspension system can cause spring, shock absorber, or brake failure, handling or steering problems, irregular tire wear, tire failure or other damage. An overloaded vehicle is hard to drive and hard to stop. In cases of serious overloading, brakes can fail completely, particularly on steep hills. The load a tire will carry safely is a combination of the size of tire, its load range, and corresponding inflation pressure. Excessive loads and/or underinflation cause tire overloading and, as a result, abnormal tire flexing occurs. This situation can generate an excessive amount of heat within the tire. Excessive heat may lead to tire failure. It is the air pressure that enables a tire to support the load, so proper inflation is critical. The proper air pressure may be found on the certification/VIN label and/or on the Tire Placard. This value should never exceed the maximum cold inflation pressure stamped on the tire.

**Trailers 10,000 Pounds GVWR or Less**



**TIRE AND LOADING INFORMATION**

The weight of cargo should never exceed   911   Kg   2,009   Lbs

TIRE	SIZE	COLD TIRE PRESSURE	<b>SEE OWNER'S MANUAL FOR ADDITIONAL INFORMATION</b>
FRONT	ST 205/75R14-C	344 kPa    50 PSI	
REAR	ST 205/75R14-C	344 kPa    50 PSI	
SPARE	ST 205/75R14-C	344 kPa    50 PSI	

Tire and Loading Information Placard

1. Locate the statement, “The weight of cargo should never exceed XXX kg or XXX lbs.,” on your vehicle’s placard. See figure 1-1.
2. This figure equals the available amount of cargo and luggage load capacity.
3. Determine the combined weight of luggage and cargo being loaded on the vehicle. That weight may not safely exceed the available cargo and luggage and load capacity.

The trailer’s placard refers to the Tire Information Placard attached adjacent to or near the trailer’s VIN (Certification) label at the left front of the trailer.

**TRAILERS OVER 10,000 POUNDS GVWR (NOTE: THESE TRAILERS ARE NOT REQUIRED TO HAVE A TIRE INFORMATION PLACARD ON THE VEHICLE).**

1. Determine the empty weight of your trailer by weighing the trailer using a public scale or other means. This step does not have to be repeated.
2. Locate the GVWR (Gross Vehicle Weight Rating) of the trailer on your trailer’s VIN (Certification) label.
3. Subtract the empty weight of your trailer from the GVWR stated on the VIN label. That weight is the maximum available cargo capacity of the trailer and may not be safely exceeded.

**Tire Safety Checklist**

Check tire pressure regularly (at least once a month), including the spare.

Inspect tires for uneven wear patterns on the tread, cracks, foreign objects, or other signs of wear or trauma.

Remove bits of glass and foreign objects wedged in the tread.

Make sure your tire valves have valve caps.

Check tire pressure before going on a long trip.

Do not overload your vehicle. Check the Tire Information and Loading Placard on User’s Manual for the maximum recommended load for the vehicle.

**Section 2**

**Steps for Determining Correct Load Limit**

1. Locate the statement “The combined weight of occupants and cargo should never exceed XXX lb” on your vehicles placard.
2. Determine the combined weight of the driver and passengers that will be riding in your vehicle.
3. Subtract the combined weight of the driver and passengers from XXX kilograms or XXX pounds.
4. The resulting figure equals the available amount of cargo and luggage capacity. For example, if the “XXX” amount equals 1400 lbs. and there will be five 150 lb. passengers in your vehicle, the amount of available cargo and luggage capacity is 650 lbs. (1400-750 (5 x 150) = 650 lbs.)
5. Determine the combined weight of luggage and cargo being loaded on the vehicle. That weight may not safely exceed the available cargo and luggage capacity calculated in Step #4.
6. If your vehicle will be towing a trailer, load from your trailer will be transferred to your vehicle. Consult this manual to determine how this reduces the available cargo and luggage capacity of your vehicle.





## Glossary of Tire Terminology

See appendix — included with glossary of common RV terms.

For further information about wheel and tire safety:

1-888-327-4236 (TTY: 1-800-424-9153).

<http://www.safercar.gov> and

NHTSA  
1200 New Jersey Avenue, SE  
Washington, DC 20590.

If you believe that your vehicle has a defect which could cause a crash or could cause injury or death, you should immediately inform the National Highway Traffic Safety Administration (NHTSA) in addition to notifying Skyline Corporation.

If NHTSA receives similar complaints, it may open an investigation, and if it finds that a safety defect exists in a group of vehicles, it may order a recall and remedy campaign. However, NHTSA cannot become involved in individual problems between you, your dealer, or Skyline Corporation.

To contact NHTSA, you may either call the Auto Safety Hotline toll-free at 1-888-327-4236 (or 366-0123 in Washington, D.C. area) or write to NHTSA, U.S. Department of Transportation, Washington, D.C. 20590. You can also obtain other information about motor vehicle safety from the hotline.

### Appendix

For assistance with this manual, warranty information or information on Skyline Products, please visit us on the web at [www.skylinecorp.com](http://www.skylinecorp.com) or contact Skyline Consumer Relations.

Address:  
P.O. Box 743  
2520 By-Pass Road  
Elkhart, IN 46514-1584

Fax: 574-522-5257  
Toll Free Phone: 1-800-755-6521  
E-Mail: [crelations@skylinecorp.com](mailto:crelations@skylinecorp.com)

Business Hours: 8:00AM - 5:00PM (ET) Monday - Friday

### Exterior Pre-Travel Checklist

- Fill the propane bottles
- Empty the holding tanks
- Connect the trailer to the tow vehicle and test all of the exterior lights
- Inspect the awning and ensure that it is properly retracted and secured for travel. It is recommended that a tie wrap be used on the awning arms preventing the possibility of the awning deploying while in travel.
- Inspect all exterior baggage doors and hatches ensuring they are locked
- Inspect the tires and check the pressures. Refer to Chapter 9
- Loosen and Torque the lug nuts. Refer to Chapter 9
- Secure the rear leveling jacks in the “up” position
- Connect the breakaway switch and test the brakes on the trailer. Adjust the tow vehicle brake controller in accordance with the manufacturer’s recommendations
- Position the battery disconnect (if equipped) to the “on” position. This is required to engage the trailer’s brakes in the event of an emergency
- Ensure the steps are retracted

### Interior Pre-Travel Checklist

- Close all vents and windows
- Place the television antenna “down” position
- Retract the slide rooms
- Inspect the interior of the unit ensuring that all cabinet, interior, and the shower doors are closed and secured
- Secure all loose items in storage compartments
- Ensure that the travel latch is closed on the refrigerator
- Test the smoke, carbon monoxide and propane alarms

**Battery**

- Check the electrolyte levels in the battery cells. Refer to Chapter 5
- Clean the battery terminals and ensure they are securely tightened. Refer to Chapter 5

**Exterior**

- Wash the exterior of the trailer at least monthly. Pay particular attention to the graphics when washing and waxing. Power buffers and high pressure washers can remove or damage the graphics. This type of damage is not covered under the warranty. Refer to Chapter 9
- Inspect the seals around the windows, doors and appliance vents. Clean and reseal as required. Refer to Chapter 9
- Remove debris from the window weep holes. Refer to Chapter 9

**Frame and Chassis**

- Inspect the frame for signs of corrosion. Clean and lightly sand any corroded areas and touch them up with good quality paint. Refer to Chapter 9
- Inspect the steps for corrosion. Clean and touch up any corroded areas. Lubricate the pivot points on the steps. Refer to Chapter 9
- Check the tire pressure. Refer to Chapter 9
- Generator - Review the preventative maintenance requirements in the manufacturer's owner manual. Refer to Chapter 4

**Plumbing**

- Flush the fresh water system and sanitize. Refer to Chapter 7
- Flush the water heater tank. Refer to Chapter 7
- Replenish the water tank air pocket. Refer to Chapter 7
- Winterize your trailer prior to the onset of freezing temperatures. During extreme freezing temperatures it is recommended that the unit be winterized. Damage to the plumbing system due to freezing is not covered under the warranty.

**Roof**

- Remove all debris from the roof and thoroughly clean using a mild detergent. Refer to Chapter 9
- Inspect the roof seals for signs of deterioration. Reseal areas as required. Refer to Chapter 9



## Glossary of Common RV Terms

**Accessory weight** - The combined weight (in excess of those standard items which may be replaced) of automatic transmission, power steering, power brakes, power windows, power seats, radio and heater, to the extent that these items are available as factory-installed equipment (whether installed or not).

**AC Electricity** - Alternating Current. Standard Household 120 Volt AC current.

**Anode Rod** - Part of the water heater that attracts impurities in the waste that cause corrosion.

**Bead** - the part of the tire that is made of steel wires, wrapped or reinforced by ply cords and that is shaped to fit the rim.

**Bead Separation** - This is the breakdown of the bond between components in the bead.

**Bias Ply Tire** - A pneumatic tire in which the ply cords that extend to the beads are laid at alternate angles substantially less than 90 degrees to the centerline of the tread.

**Black Tank** - The holding tank into which the toilet directly drains.

**Black Water** - The term associated with sewage contained within the black tank.

**Brake Controller** - Device located under the dash of a towing vehicle that controls the braking system of the trailer.

**BTU** - The measurement of the amount of heat required to raise the temperature of one (1) pound of water, one (1) degree F.

**Carcass** - The tire structure, except tread and sidewall rubber which, when inflated, bears the load.

**Chunking** - The breaking away of pieces of the tread or sidewall.

**City Water** - Refers to exterior water source, not water from the fresh water tank, that you hook up to at campgrounds. "City Water" refers to pulling water from a central source (like in a city).

**Condensation** - The result of warm humid air coming in contact with a cool surface causing water droplets to form.

**Converter** - Device that converts 120V AC to 12V DC.

**Curbside** - Term used to refer to the side of your coach, which faces the curb or shoulder when parked. Also called DOOR SIDE (the main entrance door) or OFFROAD SIDE.

**DC Electricity** - Direct current. Also termed Battery Power. Used to run all 12 Volt powered systems or lighting.

**Dry Camping** - Refers to camping using only the resources within your unit and without amenities such as city water hook-ups, electrical hook-ups, etc., often provided at commercial campsites.

**DSI Ignition** - Direct Spark Ignition — An automatic method of lighting a main burner on a propane fired appliance.

**Cold Inflation Pressure** - The pressure in the tire before you drive.

**Cord** - The strands forming the plies in the tire.

**Cord Separation** - The parting of cords from adjacent rubber compounds.

**Cracking** - Any parting within the tread, sidewall, or inner liner of the tire extending to cord material.

**CT** - A pneumatic tire with an inverted flange tire and rim system in which the rim is designed with rim flanges pointed radially inward and the tire is designed to fit on the underside of the rim in a manner that encloses the rim flanges inside the air cavity of the tire.

**Curb Weight** - The weight of a motor vehicle with standard equipment including the maximum capacity of fuel, oil, and coolant, and, if so equipped, air conditioning and additional weight optional engine. (Applies also to travel trailers and fifth wheels.)

**Ducted AC** - Air conditioning distributed through a ducting system.

**Ducted Heat** - Warm air distributed through a ducting system.

**Dual Electrical System** - Coach equipped with appliances and lights, which operate on 12V power when self-contained, and through a converter, on 120 AC when connected to shore power or run off of a generator.

**Dump Station** - Term used for locations to drain the waste holding tanks (gray and black tanks). In most states, it is illegal to dump your tanks anywhere except at dump stations.

**Dump Valve** - Another name for the T-Handle used to drain the black and gray tanks.

**Egress Window** - Term for the emergency exit windows within recreational vehicles: Usually identified by red handles or levers.

**Extra Load Tire** - A tire designed to operate at higher loads and at higher inflation pressures than the corresponding standard tire.

**Full Hook-Up Site** - A campsite that offers full amenities: City water, sewer, and electrical hook ups — many have cable and phone available.

**Galley Tank** - A gray water holding tank used specifically for the kitchen waste water.

**Generator** - Powered by gasoline or propane, generates 120 Volt power.

**Gray Tank** - The waste holding tank into which water from the kitchen and bath sinks, shower and tub drains.

**Gray Water** - Water drained into the gray holding tank.

**Groove** - The space between two adjacent tread ribs on a tire.

**Gross Axle Weight rating (GAWR)** - The value specified as the load carrying capacity of a single axle system, as measured at the tire-ground interfaces.

**Gross Combined Weight Rating (GCWR)** - Maximum load weight (in lbs.) allowed for the coach and tow vehicle.

**Gross Vehicle Weight Rating (GVWR)** - The maximum permissible weight of the fully loaded trailer.

**Hitch Weight** - The vertical trailer load supported by the hitch ball.

**Holding Tanks** - Refers to the tanks typically known as gray and black, where waste water is held.

**Hook-Ups** - Where you connect to a campground's facilities.

**Innerliner** - The layer(s) forming the inside surface of a tubeless tire that contains the inflating medium within the tire.

**Innerliner Separation** - The parting of the innerliner from cord material in the carcass (of a tire).

**Intended Outboard Sidewall** - The sidewall that contains a white-wall, bears white lettering or bears manufacturer, brand, and/or model name molding that is higher or deeper than the same molding on the other sidewall of the tire or the outward facing sidewall of an asymmetrical tire that has a particular side that must always face outward when mounted on a vehicle.

**Light Truck (LT) Tire** - A tire designated by its manufacturer as primarily intended for use on light-weight trucks or multipurpose passenger vehicles.

**Load Rating** - The maximum load that a tire is rated to carry for a given inflation pressure.

**Low Point/Low Point Drain** - Lowest point in the plumbing system. Drain valves are placed at these points for draining fresh water lines.

**Maximum Load Rating** - The load rating for a tire at the maximum permissible inflation pressure for that tire.



**Maximum Permissible Inflation Pressure** - The maximum cold inflation pressure to which a tire may be inflated.

**Maximum Loaded Vehicle Weight** - The sum of curb weight, accessory weight, vehicle capacity weight, and production options weight.

**Measuring Rim** - The rim on which a tire is fitted for physical dimension requirements.

**Net Carrying Capacity (NCC)** - Maximum weight that can be added without exceeding the GVWR. Also referred to as 'Payload Capacity'.

**Non-Pneumatic Rim** - A mechanical device which, when a non-pneumatic tire assembly incorporates a wheel, supports the tire, and attaches, either integrally or separably, to the wheel center member and upon which the tire is attached.

**Non-Pneumatic Spare Tire Assembly** - A non-pneumatic tire assembly intended for temporary use in place of one of the pneumatic tires and rims that are fitted to a passenger car in compliance with the requirements of this standard.

**Non-Pneumatic Tire** - A mechanical device which transmits, either directly or through a wheel or wheel center member, the vertical load and tractive forces from the roadway to the vehicle, generates the tractive forces that provide the directional control of the vehicle and does not rely on the containment of any gas or fluid for providing those functions.

**Non-Pneumatic Tire Assembly** - A non-pneumatic tire, alone or in combination with a wheel or wheel center member, which can be mounted on a vehicle.

**Normal Occupant Weight** - This means 68 kilograms (150 lbs.) times the number of occupants specified in the second column of Table I of 49 CFR 571.110.

**Occupant Distribution** - The distribution of occupants in a vehicle as specified in the third column of Table I of 49 CFR 571.110.

**Open Splice** - Any parting at any junction of tire tread, sidewall, or innerliner that extends to cord material.

**Outer Diameter** - The overall diameter of an inflated new tire.

**Overall Width** - The linear distance between the exteriors of the sidewalls of an inflated tire, including elevations due to labeling, decorations, or protective bands or ribs.

**Pilot** - Small flame that is used to ignite the main burner of a propane-fired appliance.

**Pin Weight** - The vertical trailer load supported by the king pin of a fifth wheel hitch.

**Ply** - A layer of rubber-coated parallel cords (on a tire).

**Ply Separation** - A parting of rubber compound between adjacent plies (of a tire).

**Pneumatic Tire** - A mechanical device made of rubber, chemicals, fabric and steel or other materials, that when mounted on an automotive wheel, provides the traction and contains the gas or fluid that sustains the load.

**Production Options Weight** - The combined weight of those installed regular production options weighing over 2.3 kilograms (5 lbs.) in excess of those standard items which they replace, not previously considered in curb weight or accessory weight, including heavy duty brakes, ride levelers, roof rack, heavy duty battery, and special trim.

**Primitive Campsite** - Campsite that offers limited or no connections. May have city water or electrical available but not both.

**Pull-Through Sites** - Campsites that you can pull your recreational vehicle through, eliminating the need to back in.

**Radial Ply Tire** - A pneumatic tire in which the ply cords that extend to the beads are laid at substantially 90 degrees to the centerline of the tread.



**Recommended Tire Inflation Pressure** - This is the inflation pressure provided by the vehicle manufacturer on the Tire Information label and on the Certification / VIN tag.

**Reinforced Tire** - A tire designed to operate at higher loads and at higher inflation pressures than the corresponding standard tire.

**Rim** - A metal support for a tire or a tire and tube assembly upon which the tire beads are seated.

**Rim Diameter** - This means the nominal diameter of the bead seat.

**Rim Size Designation** - This means the rim diameter and width.

**Rim Type Designation** - This means the industry of manufacturer's designation for a rim by style or code.

**Rim Width** - This means the nominal distance between rim flanges.

**Roadside** - Refers to the side of the unit that faces the road when parked. Also commonly referred to as "Off DOOR SIDE".

**RV** - Short for Recreational Vehicle.

**RVIA** - Recreational Vehicle Industry Association.

**Section Width** - The linear distance between the exteriors of the sidewalls of an inflated tire, excluding elevations due to labeling, decoration, or protective bands.

**Shore Line** - The electrical cord that connects 120V from an exterior outlet (such at campgrounds) to the RV. Also called 'Power Cord'.

**Shore Power** - The 120V campground outlet that the Shore Line connects to.

**Sidewall** - That portion of a tire between the tread and bead.

**Sidewall Separation** - That parting of the rubber compound from the cord material in the sidewall.

**Test Rim** - The rim on which a tire is fitted for testing, and may be any rim listed as appropriate for use with that tire.

**Tread** - That portion of a tire that comes into contact with the road.

**Tread Rib** - A tread section running circumferentially around a tire.

**Tread Separation** - Pulling away of the tread from the tire carcass.

**Tread-Wear Indicators (TWI)** - The projections within the principal grooves (of a tire) designed to give a visual indication of the degrees of wear of the tread.

**Unloaded Vehicle Weight (UVW)** - Weight of the unit without adding fuel, water, propane, supplies and passengers. Also referred to as 'Dry Weight'.

**Vehicle Capacity Weight** - The rated cargo and luggage load plus 68 kilograms (150 lbs.) times the vehicle's designated seating capacity.

**Vehicle Maximum Load On The Tire** - The load on an individual tire that is determined by distributing to each axle its share of the maximum loaded vehicle weight and dividing by two.

**Vehicle Normal Load On The Tire** - The load on an individual tire that is determined by distributing to each axle its share of the curb weight, accessory weight, and normal occupant weight (distributed in accordance with Table I or CRF 49 571.110) and dividing by 2.

**Weather Side** - The surface area of the rim not covered by the inflated tire.

**Wet Weight** - Weight of the coach with fuel, fresh water and propane tanks full.

**Wheel Center Member** - In the case of a non-pneumatic tire assembly incorporating a wheel, a mechanical device which attaches, either integrally or separably, to the non-pneumatic rim and provides the connection between the non-pneumatic rim and the vehicle; or, in the case of a non-pneumatic tire assembly not incorporating a wheel, a mechanical device which attaches, either integrally or separably, to the non-pneumatic tire and provides the connection between tire and the vehicle.

**Wheel Holding Fixture** - The fixture used to hold the wheel and tire assembly securely during testing.



# Warranty Information

## Air Conditioner

Manufacturer \_\_\_\_\_

Model \_\_\_\_\_

Serial Number \_\_\_\_\_

## Microwave Oven

Manufacturer \_\_\_\_\_

Model \_\_\_\_\_

Serial Number \_\_\_\_\_

## Stereo

Manufacturer \_\_\_\_\_

Model \_\_\_\_\_

Serial Number \_\_\_\_\_

## Generator

Manufacturer \_\_\_\_\_

Model \_\_\_\_\_

Serial Number \_\_\_\_\_

## Miscellaneous

Key Number \_\_\_\_\_

---

---

---

---

---

---

---

---



# Index

<b>12 Volt System</b> .....	34	<b>GFCI (Ground Fault Circuit Interrupter)</b> .....	37	<b>Tires</b> .....	56
<b>120 Volt System</b> .....	35	<b>Glossary</b> .....	76	Overloading.....	72
<b>7-Way Plug</b> .....	37	Tire Terminology.....	74	Pressure.....	68
<b>Air Conditioner</b> .....	24	<b>Hitch</b> .....	17	Safety.....	67
<b>Antenna, TV</b> .....	25	Couplers.....	56	Changing.....	57
Raise.....	25	<b>Holding Tanks</b> .....	48	Size, Tread, Balance	
Lower.....	25	<b>Humidity, Control</b> .....		& Repair.....	69
<b>Awning</b> .....	25	<b>Relative</b> .....	7	Fundamentals.....	70
<b>Battery</b> .....	60	<b>King Pin</b> .....	12	Information.....	70
Tow Vehicle.....	36	<b>Propane Bottles</b> .....	40	<b>Toilet</b> .....	49
Storage.....	60	<b>Propane Detector</b> .....	33, 41	Maintenance.....	49
<b>Brakes (Braking)</b> .....	21	When to Test.....	42	Troubleshooting.....	50
Adjustment.....	21	<b>Microwave</b> .....	28	<b>Torque, Wheel Nut</b> .....	57
Inspection.....	21	<b>Mold</b> .....	10	Follow-Up.....	59
Electric.....	38	Warranty.....	5	<b>Towing</b> .....	11
Braking System.....	38	Consequences of.....	10	Hitches & Towing.....	17
<b>Breakaway Switch</b> .....	38	<b>Monitor Panel</b> .....	46	Level.....	23
How to Test.....	38	<b>No Fuss Flush</b> .....	49	Speed, Stability.....	20
<b>Carbon Monoxide Detector</b> .....	33	<b>Power Cord</b> .....	35	<b>Travel Trailer</b> .....	11
<b>Carpet</b> .....	61	<b>Ramp Door</b> .....	51	Weighing.....	15
Care & Moisture		Operation.....	51	Hitching & Towing.....	17
Management.....	8	<b>Range</b> .....	29	Leveling.....	23
<b>Condensation</b> .....	7	Hood.....	29	Slide-Out Room Adjustment	
Manage Window		<b>Refrigerator</b> .....	30	& Operation.....	51
Condensation.....	8	Care & Maintenance.....	31	<b>Ventilation</b> .....	7
<b>Converter</b> .....	36	Storage.....	64	<b>Warranty</b> .....	5
<b>Fan-Tastic Vent</b> .....	26	<b>Regulator, Propane</b> .....	40	How to Obtain	
<b>Fifth Wheel</b> .....		Care & Maintenance.....	40	Warranty Service.....	5
Weighing your Unit.....	15	<b>Roof</b> .....	54	Information.....	5
Hitching & Towing.....	17	Vents.....	31	<b>Waste Water</b> .....	48
Leveling.....	23	Care & Maintenance.....	54	<b>Water Heater</b> .....	44
Slide-Out Room Adjustment		<b>Safety Chains</b> .....	19	Draining.....	45
& Operation.....	51	<b>Slide-Out</b> .....	51	<b>Water Heater</b>	
Coupler.....	56	Adjustment.....	51	<b>By-Pass</b> .....	46
<b>Fire Safety</b> .....	31	<b>Smoke Detector</b> .....	33	<b>Water Pump</b> .....	42
Reminders.....	32	<b>Stabilizing Jacks</b> .....	23	<b>Weighing, Unit</b> .....	15
<b>Fresh Water</b> .....		<b>Storage</b> .....	16, 64	<b>Weight Rating</b>	
Tank.....	43	Areas.....	8	Definitions.....	12
Fill, Sanitizing.....	43, 44	RV.....	9	Federal Certification Label...	13
<b>Furnace</b> .....	26	Battery.....	60	GVWR (Gross Vehicle	
<b>Generator</b> .....	28			Weight Rating).....	12
				GAWR (Gross Axle	
				Weight Rating).....	12
				UVW (Unloaded	
				Vehicle Weight).....	12
				CCC (Cargo Carrying	
				Capacity).....	12
				Labels.....	12
				Weighing Your Unit.....	15
				<b>Winterization</b> .....	46

# **Skyline Recreational Vehicle Manufacturing Locations**

## *California*

### **LAYTON TRAVEL TRAILERS**

P.O. Box 2195  
425 S. Palm  
Hemet, CA 92543-5834  
1-800-733-4250  
1-951-925-0401

### **NOMAD TRAVEL TRAILERS**

P.O. Box 933  
920 W. Mayberry St.  
Hemet, CA 92543-5834  
1-888-442-0997  
1-951-658-7106

## *Texas*

### **SKYLINE RV DIVISION**

P.O. Box 119  
606 S. Second Ave.  
Mansfield, TX 76063-1917  
1-800-962-7773  
1-817-477-3161

## *Indiana*

### **NOMAD/LAYTON - ELKHART, IN**

P.O. Box 1068  
401 C.R. 15  
Elkhart, IN 46516-9623  
1-800-736-2573  
1-574-294-2573

### **MALIBU RV - ELKHART, IN**

P.O. Box 988  
411 C.R. 15  
Elkhart, IN 46516-9623  
1-800-693-6207  
1-574-293-2938

### **SKYLINE CORPORATE OFFICE**

P.O. Box 743  
2520 By-Pass Road  
Elkhart, IN 46514-1584  
1-800-755-6521  
1-574-294-6521  
[crelations@skylinecorp.com](mailto:crelations@skylinecorp.com)

# CORPORATE MISSION STATEMENT

*Skyline Corporation is a leader in the development, manufacture, and marketing of high quality, innovative manufactured homes and recreational vehicles that meet customer needs for housing and leisure lifestyles.*

*Our mission is to continually improve the quality of our products and the way we do business in order to meet customers' expectations. By pursuing this mission, we will be able to grow and prosper as a business, provide stable employment and a high quality of work life for our people, be a responsible community citizen, and return a reasonable profit to our shareholders.*

*Our mission reflects our deeply held Corporate values and principles and its achievement involves these areas:*

## **SAFETY...**

*We will provide a safe work environment for our people and safe products for our customers.*

## **QUALITY...**

*We will provide products and services that consistently meet customer needs and exceed expectations for quality.*

## **CONTINUOUS IMPROVEMENT...**

*We will continually strive for excellence in everything we do. We will constantly seek day-to-day and long-term improvements and not settle for short-term "fixes."*

## **CUSTOMER FOCUS...**

*Customers are the ultimate reason Skyline is in business and everyone at Skyline must direct his or her efforts to the production of products that exceed customer expectations. Every activity and every job in the Company is part of this process.*

## **PEOPLE...**

*People are our greatest asset. We will listen to and respect ideas from everyone and will involve our people in the decisions that affect the areas in which they work. We will continually encourage and provide training and educational opportunities for our people, so that they can optimize their performance, their individual development, and their contribution to the Company.*

## **TEAMWORK...**

*Teamwork is the driving force of the Skyline organization, enabling us to coordinate the Company's resources to achieve the Company's mission. The essence of teamwork is breaking down barriers between departments and treating each person and each job as a customer whose needs must be met if the ultimate customer, the buyer of a Skyline product, is to be satisfied.*

## **INTEGRITY...**

*We will conduct all of our activities in a manner which is at all times fair, moral, ethical, and legal. We will hire, reward and promote without discrimination and without regard to age, sex, ethnic origin, physical condition, or religious belief.*

## **DEALERS & SUPPLIERS...**

*We view our dealers and suppliers as extensions of our Company. We will conduct our business in an atmosphere of trust and work to form mutually beneficial long-term partnerships.*

## **PROFITS...**

*Profits are the ultimate measure of how efficiently we satisfy our customers' desire for products of superior value. We will strive to achieve the profits required for survival and growth and to provide jobs and security for our people.*



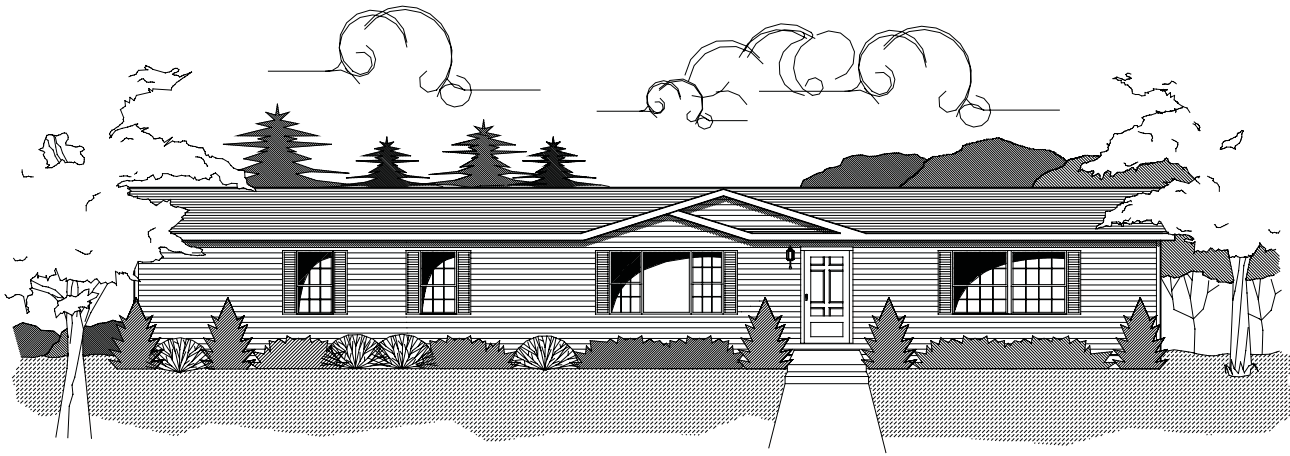

## **WHEN YOU'RE READY TO HEAD FOR HOME**

Of course, you love the RV lifestyle. And your Skyline-built RV. But you still need a home base. A place you can head for when your holiday is history.

You need a home loaded with style, comfort, and convenience. A low-maintenance home with all the space and features you want. At a price you can afford.

So if you're thinking about owning a home that won't own you, it's time to check out the homes built and backed by Skyline. For more than 57 years, Skyline's been building America's best. Because Skyline people understand that even for an RVer, nothing's more important than home sweet home.

For the name of your nearest retailer of Skyline-built homes, write Marketing Department, Skyline Corporation, Post Office Box 743, Elkhart, Indiana 46515-0743. Or visit us at our Web Site, at [www.skylinecorp.com](http://www.skylinecorp.com).

© 2008 Skyline Corporation, Elkhart, Indiana

**SKYLINE**<sup>®</sup>  
BRINGING AMERICA HOME. BRINGING AMERICA FUN.

Corporate Office — P.O. Box 743 — Elkhart, Indiana 46515-0743  
1-800-755-6521

**Visit us at our web site at [www.skylinecorp.com](http://www.skylinecorp.com)**

05/15/08